

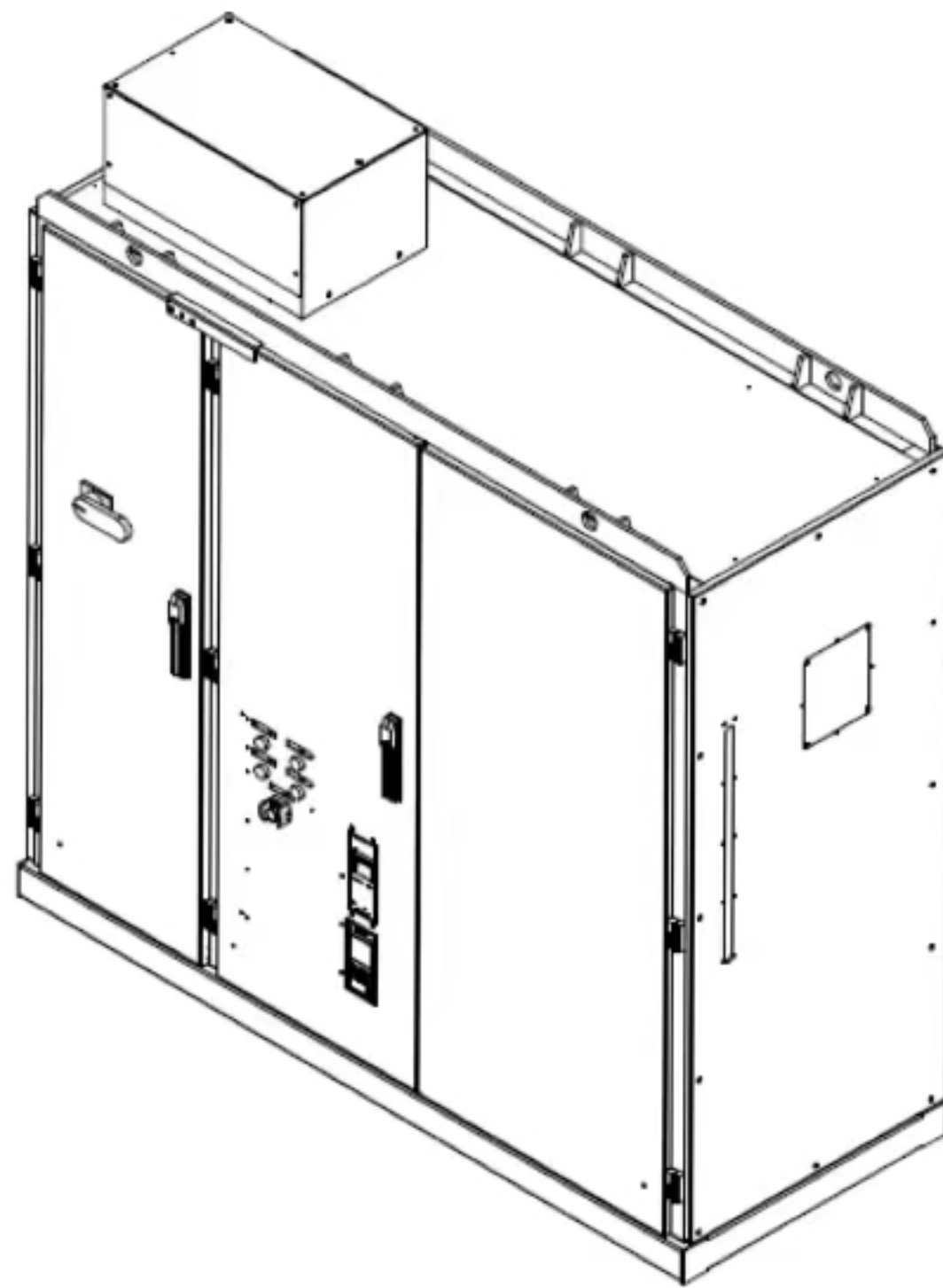

YD 系列  
空调专用变频器用户手册

乐金空调（山东）有限公司设计监制



# Contents

<b>Chapter 0 Instruction .....</b>	<b>0-1</b>
<b>Chapter 1 Safety Precautions .....</b>	<b>1-1</b>
1.1 Before Power On .....	1-1
1.2 After Power On.....	1-1
1.3 Wiring.....	1-2
1.4 Before Operation.....	1-2
1.5 Parameter Setting .....	1-3
1.6 Operation .....	1-3
1.7 Inspection, Maintenance and Replacement .....	1-4
<b>Chapter 2 Model Instruction And Model name description .....</b>	<b>2-1</b>
2.1 Nameplate.....	2-1
2.2 Power Selection And Appearance Size.....	2-1
2.3 Model name description .....	2-2
2.4 AFE (Rectifier Feedback) And Inv. (Inverter) Control Board Wiring Diagram .....	2-5
2.5 External Terminal And Wire Number Diagram .....	2-5
2.6 Wiring Diagram Of Automatic Backwash Cleaning (Optional) Of Cooling Water Filter .....	2-6
<b>Chapter 3 Surrounding Environment and Installation .....</b>	<b>3-1</b>
3.1 Environment.....	3-1
3.1.1 Running Environment... ..	3-1
3.1.2 Installation Location.....	3-1
3.2 Dimension And Mounting Holes Position .....	3-2
3.2.1 LG-AFE-520-660A Model.....	3-2
3.2.2 LG -AFE-661-990A Model .....	3-6
3.2.3 LG -AFE-991-1386A Model.....	3-10
3.2.4 Inverter Panel Peripheral Equipment Wiring And Attentions .....	3-14
3.3 Connection Between Machine Sets And Inverter Panel.....	3-15
3.3.1 Mainframe Components.....	3-15
3.3.2 Inverter Panel Cooling Pipeline.....	3-17
<b>Chapter 4 Inverter Panel Operation .....</b>	<b>4-1</b>
4.1 Instructions For LCD Panel Of Inverter .....	4-1
4.1.1 Keypad Function Instruction.....	4-1
4.1.2 Main Monitoring Parameters .....	4-2
4.1.3 Common Parameter Setting Table Of Inverter.....	4-2
4.1.4 Display Instructions.....	4-4
4.2 Motherboard Terminal Wiring Diagram .....	4-5
4.3 Alarm And Warning .....	4-6
4.3.1 Alarm .....	4-6

4.3.2 Warning.....	4-7
<b>Chapter 5 AFE Panel Operation .....</b>	<b>5-1</b>
5.1 AFE LCD Panel Usage Instruction .....	5-1
5.1.1 Panel Function Instruction.....	5-1
5.1.2 Keypad Definition .....	5-1
5.1.3 AFE Switching Mode .....	5-2
5.1.4 Mode Switching Way.....	5-2
5.1.5 The Process Of Modifying Parameter Values Is As Follows .....	5-3
5.1.6 Main Monitoring Parameters .....	5-3
5.1.7 Default Setting Of Parameter Table Under Different Models .....	5-5
5.1.8 Indicator Light Of Operation And Stop Key .....	5-9
5.1.9 Indicator Light Of Operation Mode .....	5-9
5.2 Mainboard Terminal Wiring Diagram.....	5-10
<b>Chapter 6 Abnormal Diagnosis And Troubleshooting.....</b>	<b>6-1</b>
6.1 Inverter Panel General Rules .....	6-1
6.2 Status Information .....	6-3
6.3 Fault Alarm (Fault) Detection Function - 【Inverter Shutdown】 .....	6-4
6.4 Warning Alarm / Self-Diagnosis Detection Function - 【Inverter Running】 .....	6-9
<b>Chapter 7 AFE Abnormal Diagnosis And Troubleshooting .....</b>	<b>7-1</b>
7.1 AFE General Rules .....	7-1
7.2 Error Display And Resolution .....	7-1
7.3 OPE Error Details .....	7-3
7.4 CPF Error Details .....	7-3
7.5 Alarm Display Details .....	7-4
<b>Chapter 8 Daily Use And Regular Maintenance.....</b>	<b>8-1</b>
8.1 Daily Use.....	8-1
8.1.1 Daily Startup .....	8-1
8.1.2 Seasonal Switch.....	8-1
8.1.3 Anti Condensation Operation Of Inverter Panel .....	8-1
8.2 Maintenance .....	8-1
8.2.1 Filter Cleaning Method And Period .....	8-1
8.2.2 Maintenance, Cleaning And Replacement Of Plate .....	8-3
8.2.3 Replacement period of coolant, coil and water pump .....	8-4

# Chapter 0 Instruction

## 0.1 Instruction

In order to make use of the inverter panel and ensure the safety of users, please read the operational manual. When you meet some difficulties in using of it, please contact the local dealers or our company technical staff, our professionals will be glad to help you.

### ※ Notice for Use.

The inverter is a sophisticated electrical and electronic product. In order to ensure the safety of your life and property, this manual contains the words "Warning" "Attention", which is for reminding you the safety precautions when you are carrying, installing, using, and checking the inverter. Please cooperate and comply with.



Mishandling may cause serious personal injury.



Mishandling may cause the damage to the inverter or mechanical system

### **Warning**

- Avoid sensitive electricity! The DC capacitor in the cabinet cannot be discharged within 15 minutes after the power is removed. Please remove or check the power supply 15 minutes after the power is removed.
- Do not implement wiring during the power transmission process, and do not open the box to inspect the circuit when the is in operation;
- Please do not disassemble and assemble or change the internal connecting lines or wiring and parts of the inverter;
- The ground terminal should be sure grounding correctly.

### **Attention**

- Please do not test the internal components of the inverter, these semiconductor parts are vulnerable to high pressure and damaged;
- Never connect the inverter output terminals U, V, W to the AC power supply;
- CMOS integrated circuit board of inverter is vulnerable to electrostatic influence and damage. Do not touch circuit boards.

# Chapter 1 Safety Precautions

## 1.1 Before Power On



### Warning

- The main circuit and terminal cable connection must be correct, three input terminals (R, S, T) for power supply, absolutely Can't mix with the motor output (U, V, W); if so, will damage inverter panel.



### Attention

- The selection of power supply voltage must be the same as the input voltage of the inverter panel specifications.
- Carrying inverter cabinet, please ensure that the fixing hole will buckle hook machine specified, and confirm tonnage forklift or lifting for handling, In order to prevent the inverter panel transportation process fall off, or causes the personal injury or inverter panel damage.
- Please install the inverter panel on noncombustible materials such as metal. Please do not install it on or near flammable materials to prevent fire.
- Please remove or install the operator after closing the power supply. Operating the keypad according to the diagram so as to avoid bad contact and cause malfunction or no display of the operator.
- In some circumstances, the use of this product may cause electromagnetic interference, so before use, please conduct proper testing, and be sure grounding properly.

## 1.2 After Power On



### Warning

- Do not open the doors after inverter panel is powered on, otherwise there is the risk of electric shock! Do not touch any input and output terminals of inverter panel. Otherwise there is danger of electric shock!
- Touching the machine body, it is best to wear insulated shoes or gloves. Avoid wet hands touching any part of the machine, causing injuries.



### Attention

- If you need to modify the parameters of inverter panel, please to check motor rotation. Otherwise, it may cause accidents.
- Do not touch the heat sink.

## 1.3 Wiring



### Warning

- Be sure to turn off the main power supply before connecting any of cable of inverter panel to avoid electric shock and fire.
- The install person should have the relevant professional knowledge to avoid electric shock or injury.
- The distribution of cooling water required to have relevant professional knowledge and documents, to avoid the danger caused by improper placement.
- To confirm connection between the ground wire and earth. (class 400V: ground impedance needs less than 10 ohms)
- The wiring is completed, to confirm the emergency stop function effectively. (the duty of the power cable connection belongs to customer installation)
- Do not touch the input / output power line. Please be aware of short circuit of all wire connection.
- Do not withstand voltage test of the inverter cabinet without professional engineer, it may cause the semiconductor component damage.



### Attention

- To confirm the main input power match up with inverter cabinet, avoid injury or fire.
- Please lock the terminal screws according to the specified torque in order to avoid the danger of fire.
- Please install the water and external cooling equipment according to the regulations to avoid the overflow of coolant or the burst of water pipe.
- Do not connect the input power to the output terminal of the frequency converter.
- Do not connect the electromagnetic contactor and the electromagnetic switch to the output terminal.
- Do not connect the incoming capacitor or the LC/RC filter to the output circuit.
- Ensure that interference from inverter cabinets and motors does not affect the peripheral sensors or equipment.

## 1.4 Before Operation



### Warning

- Before power on, please confirm that the capacity of the inverter panel is the same as the capacity of the motor being dragged.
- The cable connection between the inverter and the motor is over 25 meters, and the carrier frequency needs to reduce or the output filter needs to install to reduce the over voltage or fluctuation of the output, so as to avoid the motor damage.

- Check the waterway equipment to ensure that the water pressure and flow of the outer loop meets the cooling requirements.

## 1.5 Parameter Setting



### Attention

- Before setting parameters, please read the instruction manual.
- Professional or qualified technical certification persons are required to avoid the damage to the machine or personnel in commissioning process.

## 1.6 Operation



### Warning

- Please confirm the front door closed and turn the doorknob to the closed position, before turning on the power.
- During operation, the motor cannot be connected or disconnected. Otherwise it will seriously cause inverter damaged.
- Please do not touch the chiller after resetting the error message. The inverter will automatically restart after the fault has been cleared.
- Do not operate inverter panel in wet hands.
- Please confirm that the running command is open before resetting the error message.
- If you choose to automatically restart after restoration, the inverter will start automatically in power recovery.
- During operation, please ensure the peripheral water system working properly, avoid direct contact with electrical equipment.
- During operation, the water-cooling equipment shall NOT be disassembled or repaired, so as to avoid internal hot circulating liquid overflow.
- Regardless of the inverter in operation or stop, avoid touching relevant terminals, in case of danger.
- After the power is off, the fan may continue to spin for 20s.
- After the machine has stopped running, the panel maybe still remains high temperature, and the maintenance person should be careful to prevent scalding.



### Attention

- Please do not touch the heating components such as power line, motor cable and water cooling pipe. 
- The inverter panel can easily move the motor from low speed to high speed. Please confirm the allowable range of the motor.
- To proper adopting the circuit breaker or electromagnetic contactor to the front end,

please pay attention to the specifications and related settings.

- Please do not check the signal on the circuit board when the inverter is operating.



### **Warning**

- Avoid sensitive electricity! The DC capacitor in the inverter cabinet cannot be discharged within 20 minutes after the power is removed. Please remove or check the power supply 20 minutes after the power is removed.

## **1.7 Inspection, Maintenance and Replacement**



### **Warning**

- Before the maintenance check, make sure the power is off and the power indicator turned off (please confirm that the DC voltage is not more than 25 volts).
- There is a high voltage bus bar inside inverter panel, please do not touch it all the time.
- If the power is on, make sure to install the protective cap. After removing the protective cap, make sure to turn off circuit breaker.
- Do NOT execute maintenance, inspection, or replacement of parts, except for designated professionals.



### **Attention**

- The temperature around inverter panel should be used at 0, ~+40, 90%RH and no condensation. However, it is necessary to ensure that there is no dropped water and metal dust in the surrounding environment.

## **Precautions for Inverter Panel Scrap**



### **Attention**

- While the inverter panel is to be scrapped, please treat it as industrial waste, and please pay attention to the following items:
- The electrolytic capacitor of inverter panel and the electrolytic capacitor on the printed circuit board may explode when burned;
- The internal wires, panels and other plastic parts of the frequency converter cabinet produce poisonous gas when burning.



# Chapter 2 Model Instruction And Model name description

## 2.1 Nameplate

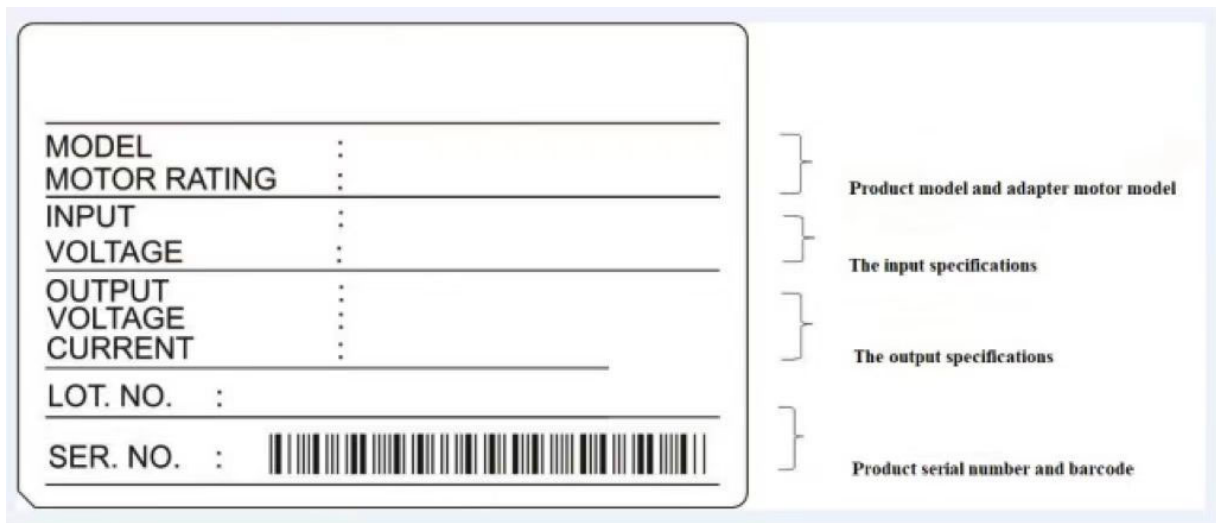

## 2.2 Power Selection And Appearance Size

Mode (The Max. Power Of The Same Frame As Example)	Applicable Power Range		Outline Size	
	Min (A)	Max (A)	H x W x D (mm)	Frame
YD0605DST38- CM2XXXSFAA00	303	605	1557x1413x785	F1
YD0906DST38- CM2XXXSFAA00	606	906	1780x1700x894	F2
YD1386DST38- CM2XXXSFAA00	907	1386	1975x1900x989	F3

## 2.3 Model name description

YD 0906 QS T40-A M 1 X X X S F A A 00  
①      ②      ③      ④   ⑤   ⑥   ⑦   ⑧   ⑨   ⑩   ⑪   ⑫   ⑬   ⑭   ⑮

① YD series VFD

② Use Motor Rated Load Amps (NMRA) value

0236: 0~236A

0302: 237~302A

0472: 303~472A

0605: 473~605A

0708: 606~708A

0906: 709~906A

1100: 907~1100A

1236: 1101~1236A

1237: 1237~1386A

③ Type of cooling

QS=Cooling water cooling system

DS=Chilled water cooling system

LM= Refrigerant cooling system

FL =Air cooling system

YF = Liquid & Air cooling system

④ Input voltage

T38= 380V-50/60Hz-3Ph

T40= 400V-50/60Hz-3Ph

T41= 415V-50/60Hz-3Ph

T44= 440V-50/60Hz-3Ph

T48= 480V-50/60Hz-3Ph

⑤ Customer Code

A=LG Qingdao

C=LG South Korea

⑥ The circuit breaker model

A= ACB

M=MCCB

⑦ Terminal model

1= Each terminal one hole

2= Each terminal two holes

3= Aluminum Terminal

⑧ Power meter optional

X= None

W= Power meter optional

⑨ Current meter and Voltage meter optional

X= None

B= Current meter and Voltage meter optional

⑩ Input reactor optional

X= None

R= Input reactor optional

⑪ SPD optional

X= None

S= SPD optional

⑫ Low harmonic optional

X= None

F=AFE optional

P=APF optional

⑬ Chiller type

A= H-model

B=Magnetic Bearing

⑭ Version code

⑮ Non-standard code

## 2.4 AFE (Rectifier Feedback) And Inv. (Inverter) Control Board Wiring Diagram

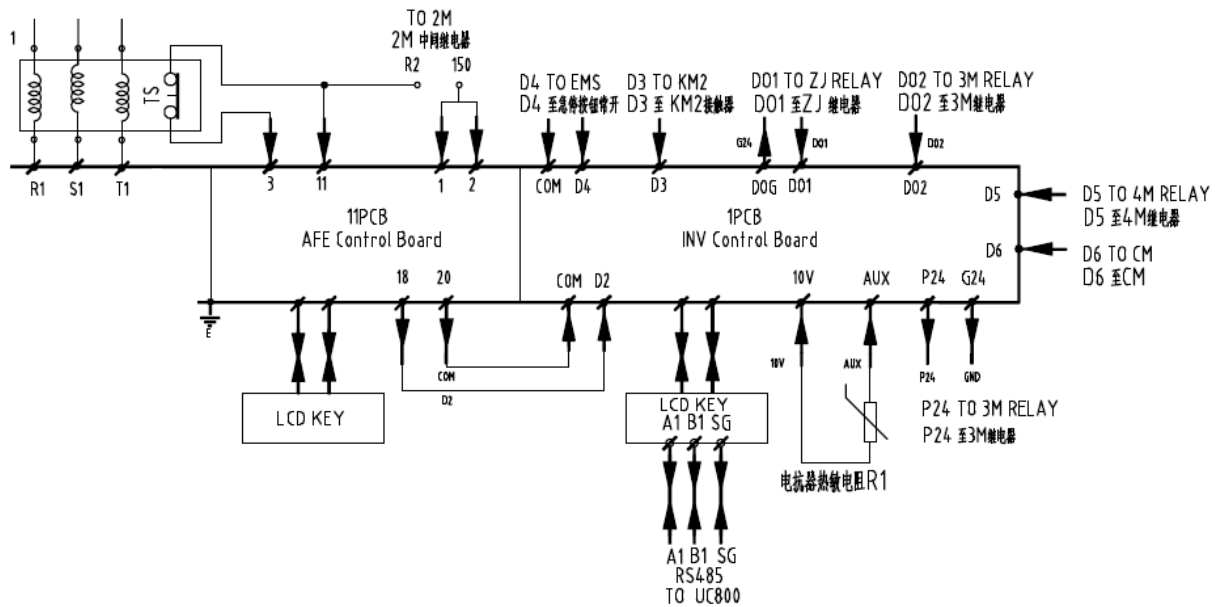

## 2.5 External Terminal And Wire Number Diagram

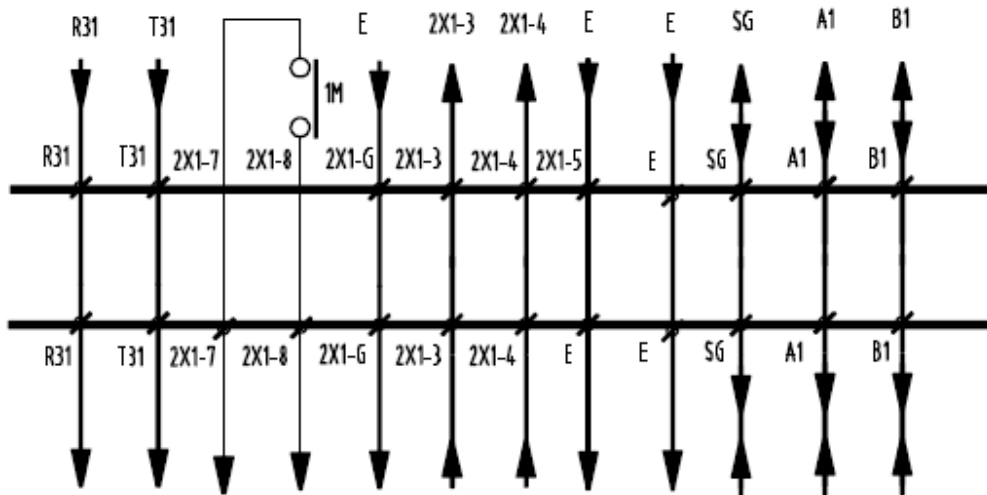

## 2.6 Wiring Diagram Of Automatic Backwash Cleaning

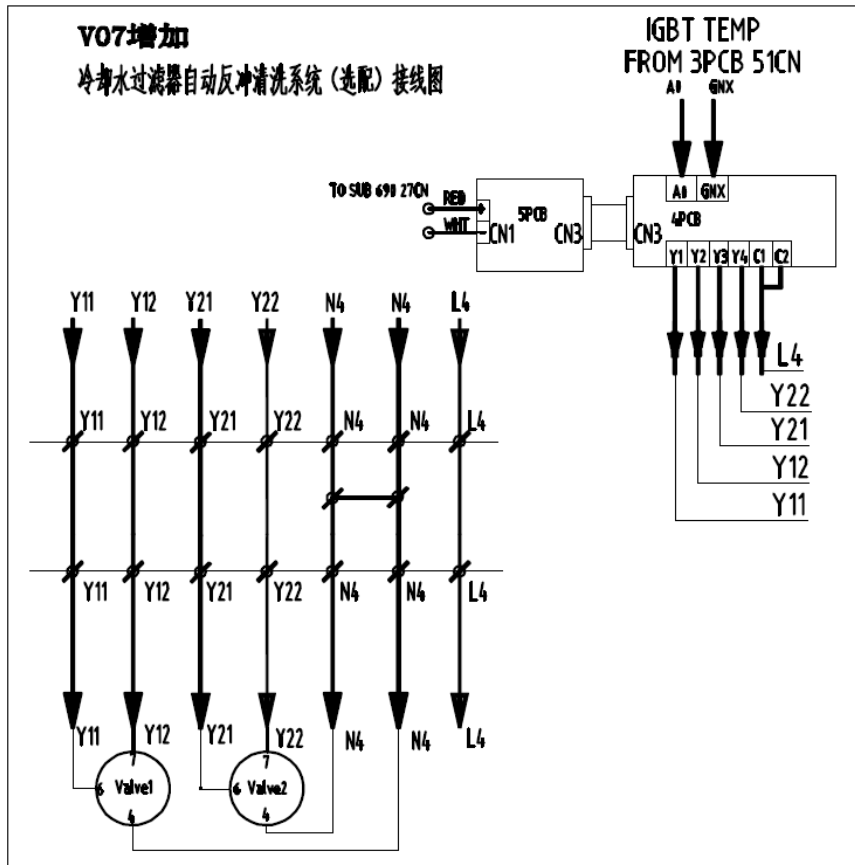

(Optional) Of Cooling Water Filter

# Chapter 3 Surrounding Environment and Installation

## 3.1 Environment

### 3.1.1 Running Environment

The installation environment of inverter panel cabinet can direct influence on the function and life span. Therefore, the installation environment of frequency converter cabinet must meet the following conditions:

Protection	
Protection Level	IP21/IP54
Applicable Environment	
External Circulating Coolant Temperature	15~40°C
Storage Temperature	-40~60°C
Humidity	5% to 90% relative humidity RH (follow IEC60068-2-78 standard)
Shake	Maximum acceleration : 1.2G (12m/s <sup>2</sup> ), from 49.84 to 150 Hz Displacement amplitude : 0.3mm (peak value), from 10 to 49.84 Hz (follow IEC60068-2-6 standard)
Altitude	Below 2000 meters above sea level, frequency converter does not drop capacity. Above 2000 meters above sea level, 100 meters per rise, inverter down 1%.

### 3.1.2 Installation Location

Products should be installed in an easy to operate environment and avoid exposure to the following circumstances:

- To avoid direct sunlight.
- To prevent the rain dripping.
- To prevent the erosion of salt, oil mist.
- To prevent the corrosive liquid and gas.
- To prevent dust, cotton and Metal filings invasion.

- To prevent electromagnetic interference (welding machine, power machine).
- Keep away from radioactive materials and combustibles.
- To prevent vibration, if not avoid, please install shock proof gasket to reduce vibration.

## 3.2 Dimension And Mounting Holes Position

### 3.2.1 LG-AFE-520-660A Model

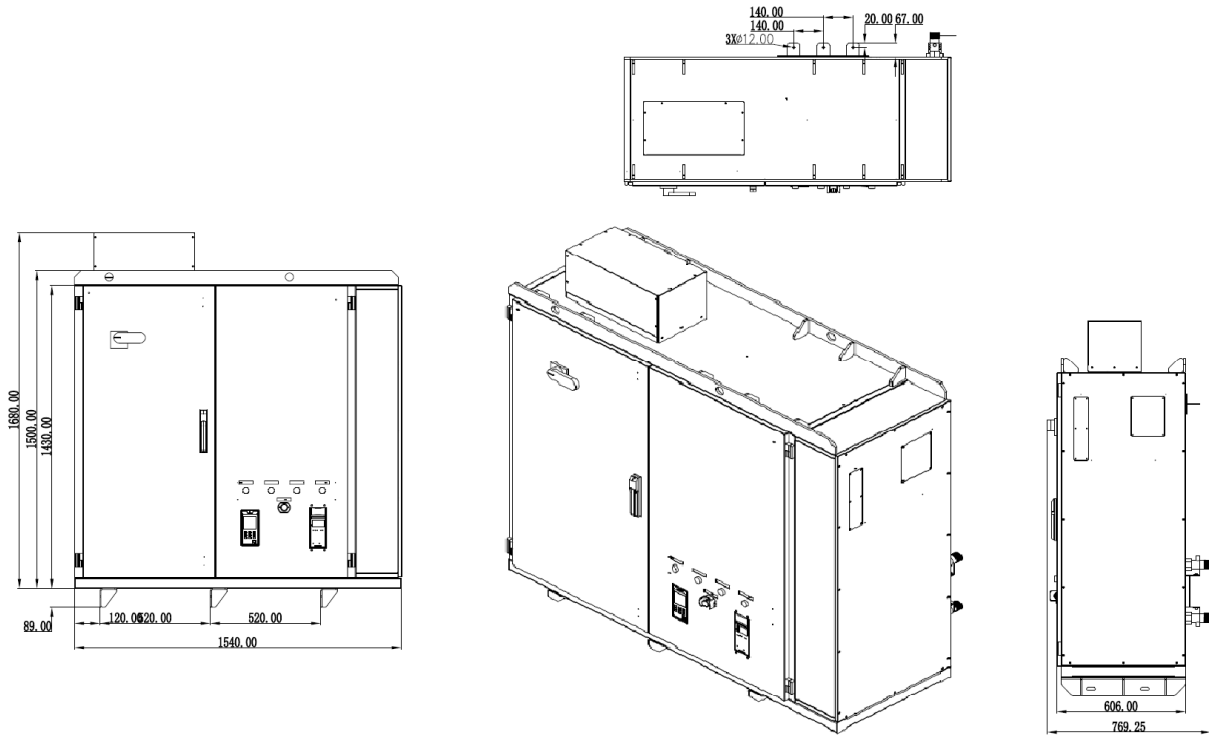

Figure 1: front appearance

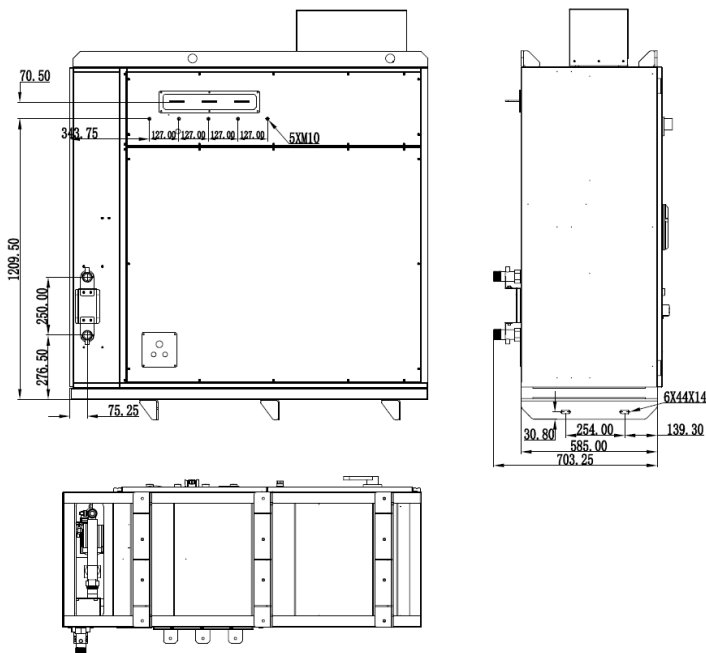

Figure 2: back appearance



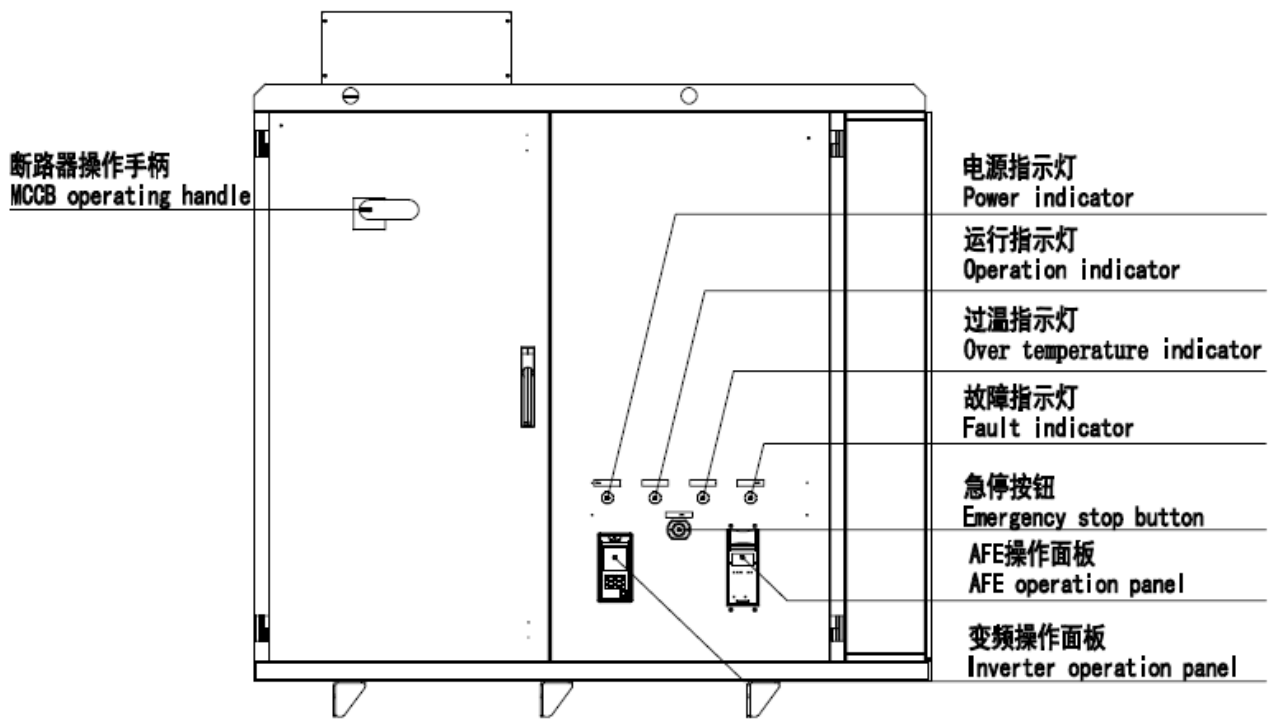

Figure 3: front controls

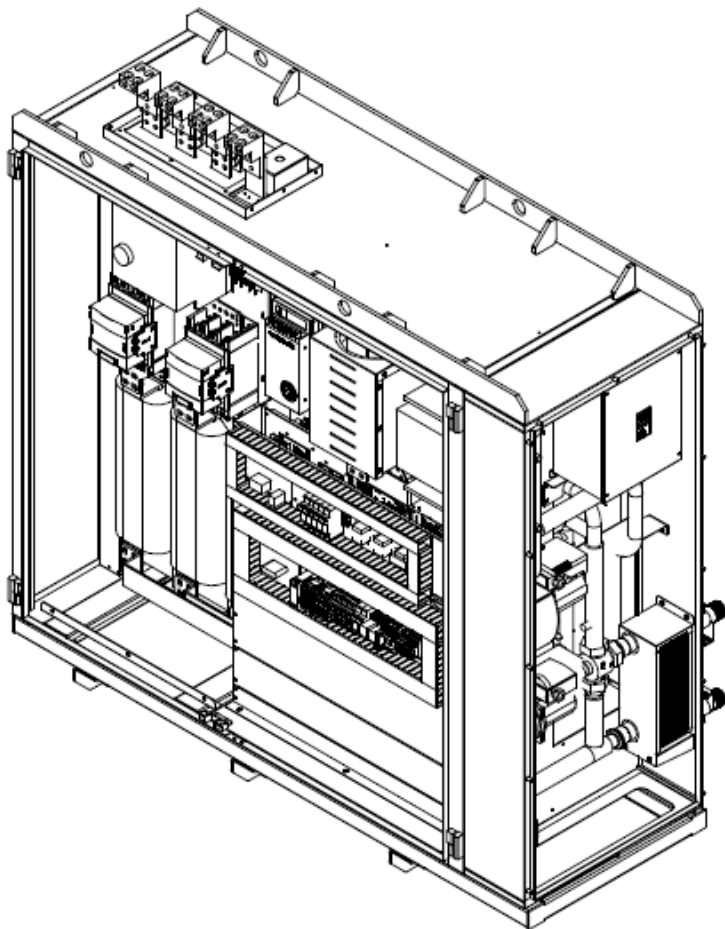

Figure 4: side naked door illustration

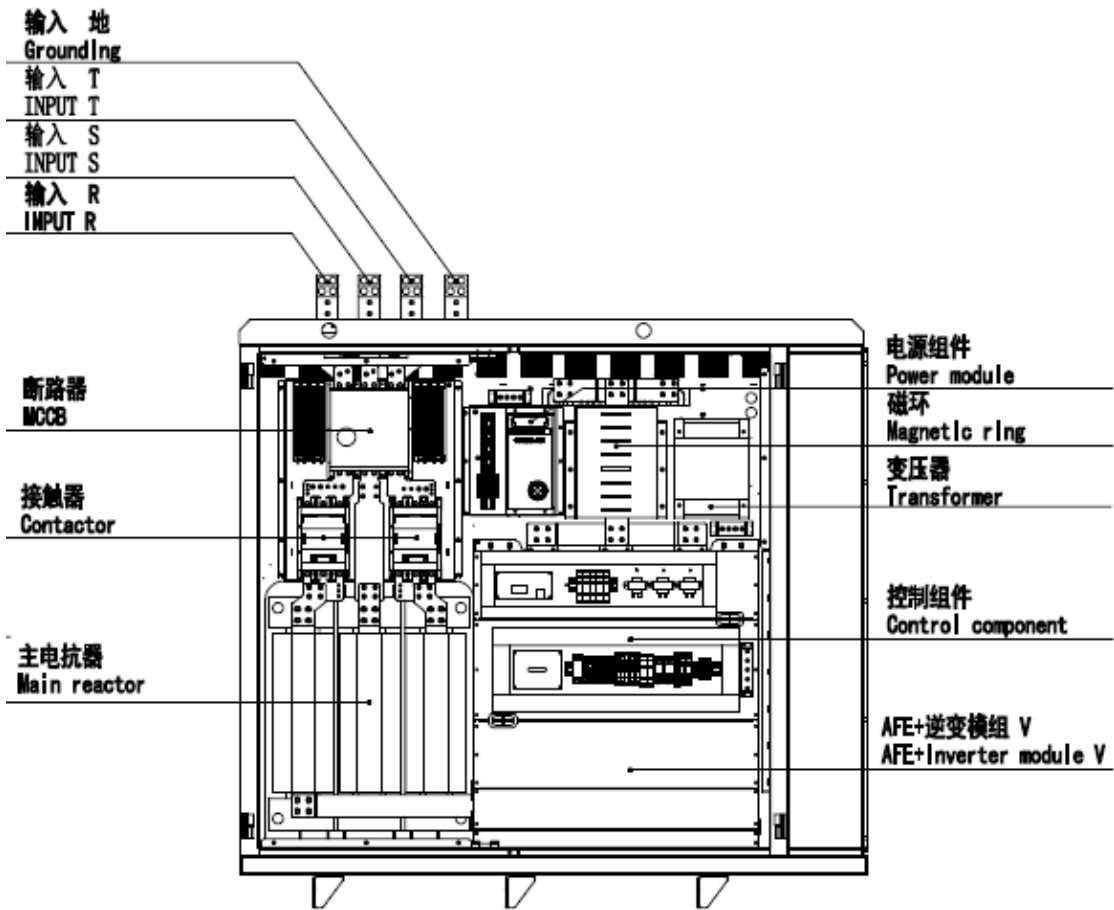

Figure 5: front naked door illustration

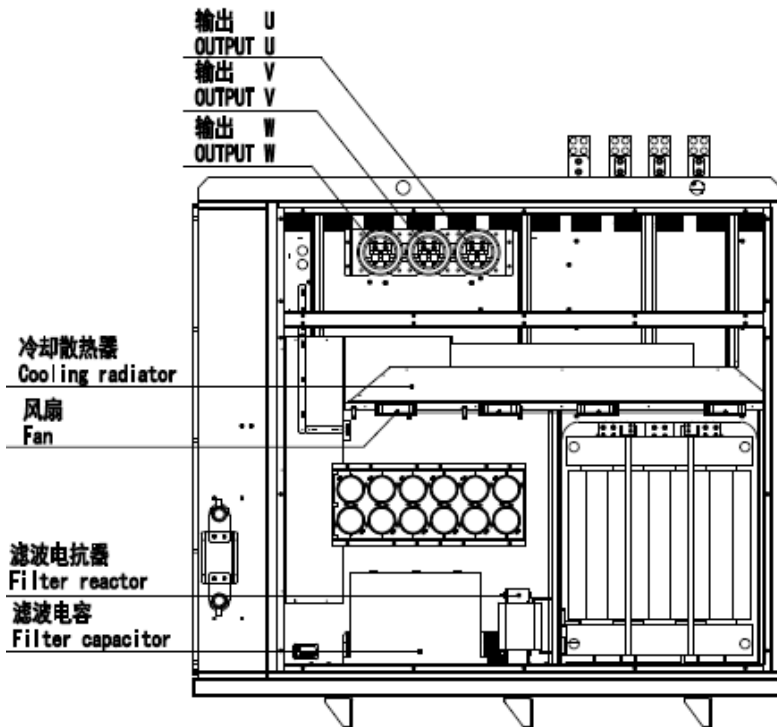
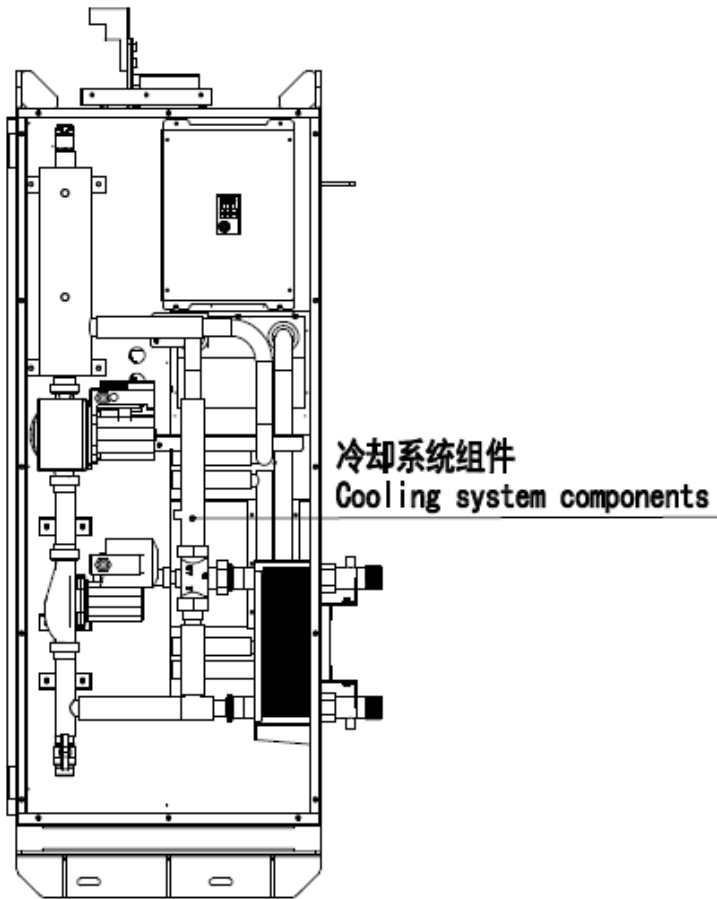
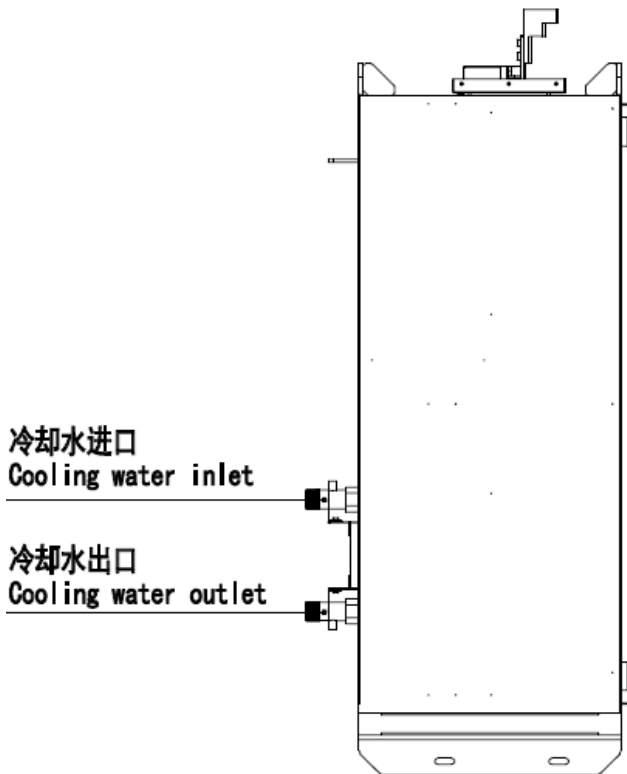

Figure 6: diagram of the rear naked door



*Figure 7: right side cooling components*



*Figure 8: inlet and outlet of cooling water on the left side*

### 3.2.2 LG-AFE-661-990A Model

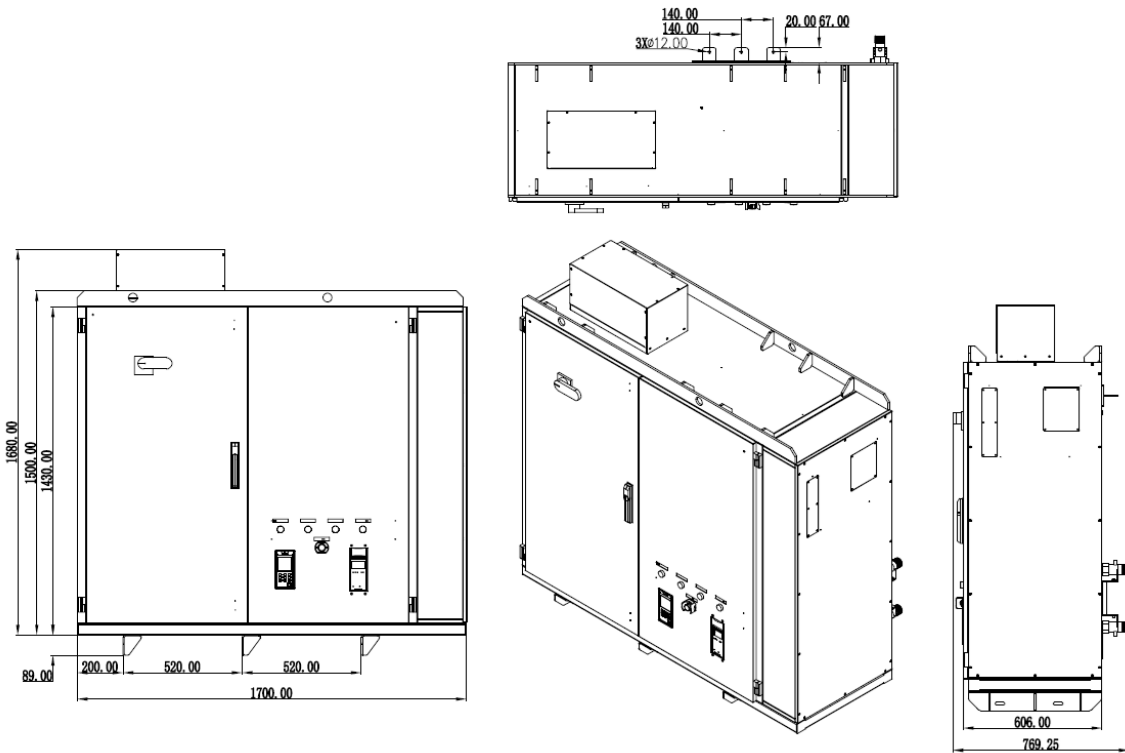

Figure 9: front appearance

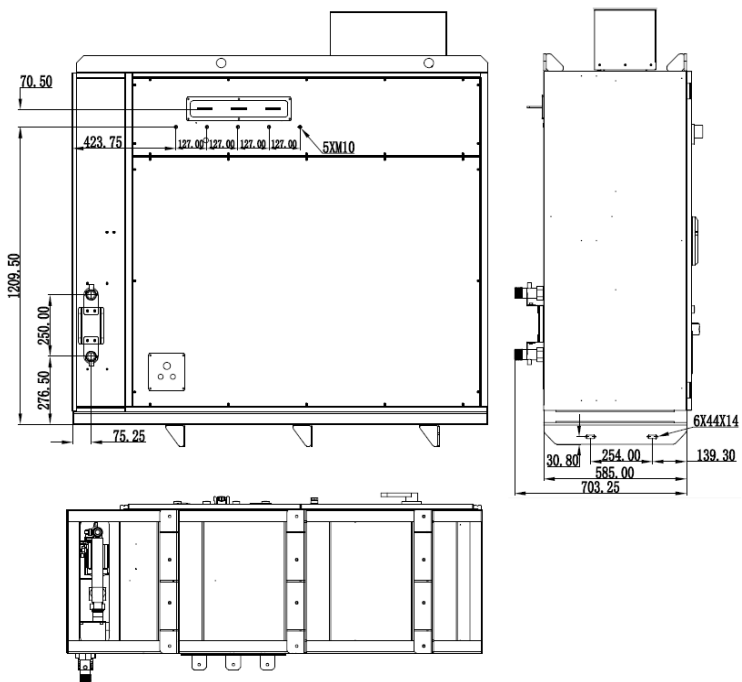

Figure 10: back appearance

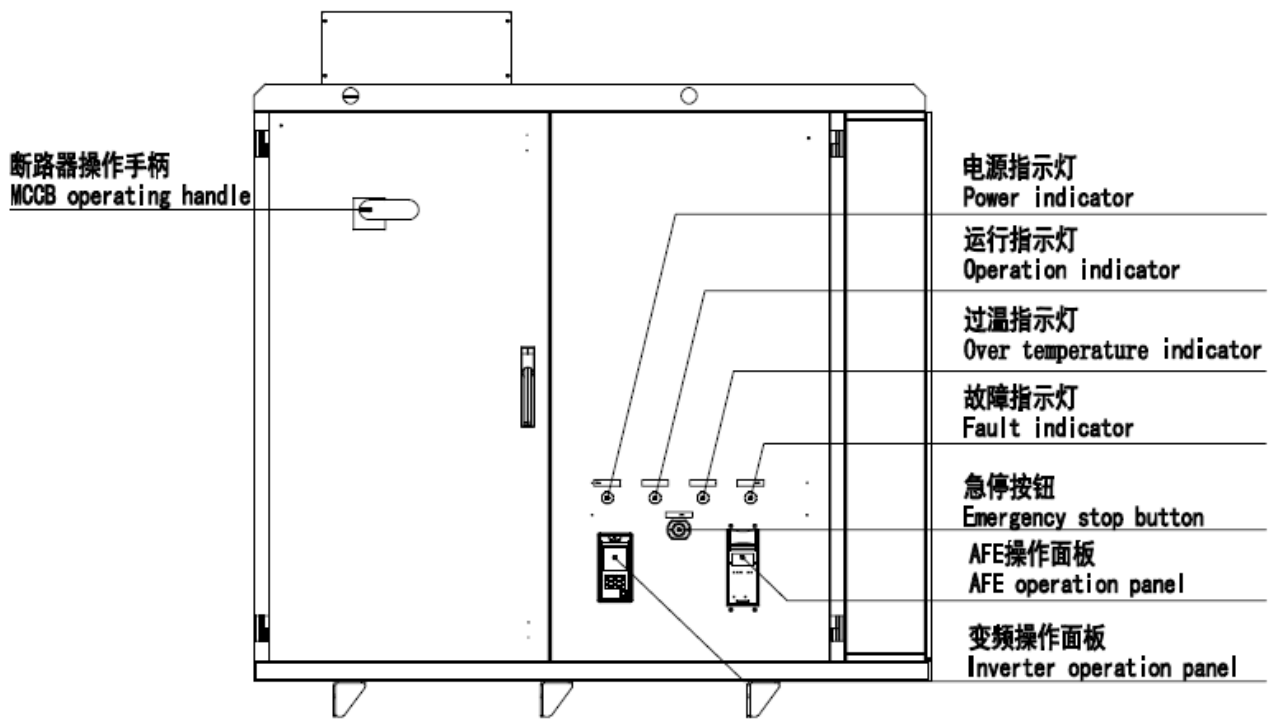

Figure 11: front controls

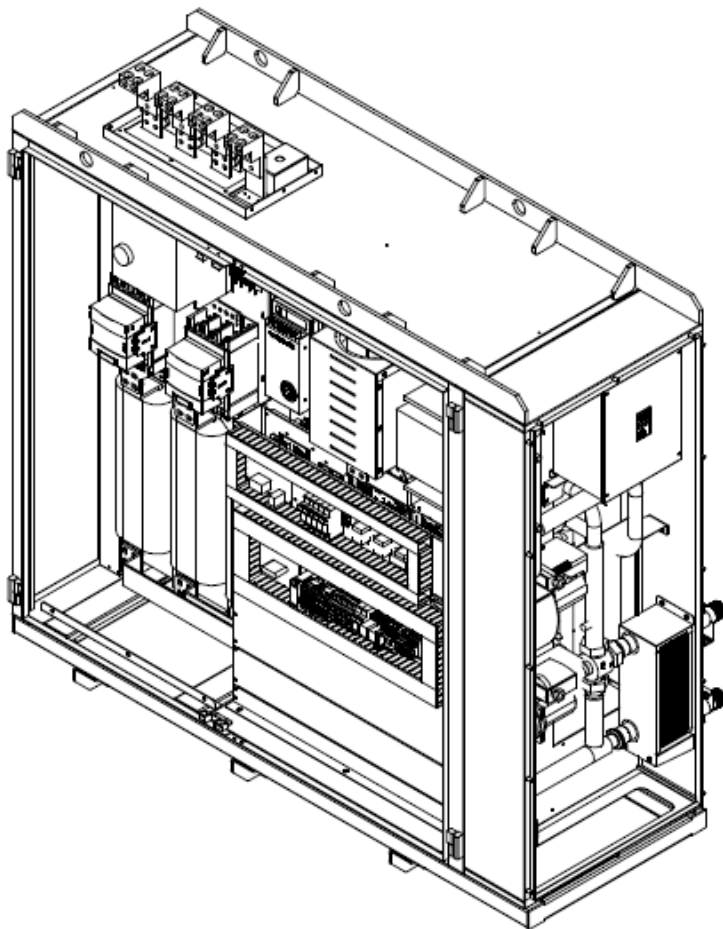

Figure 12: side naked door illustration

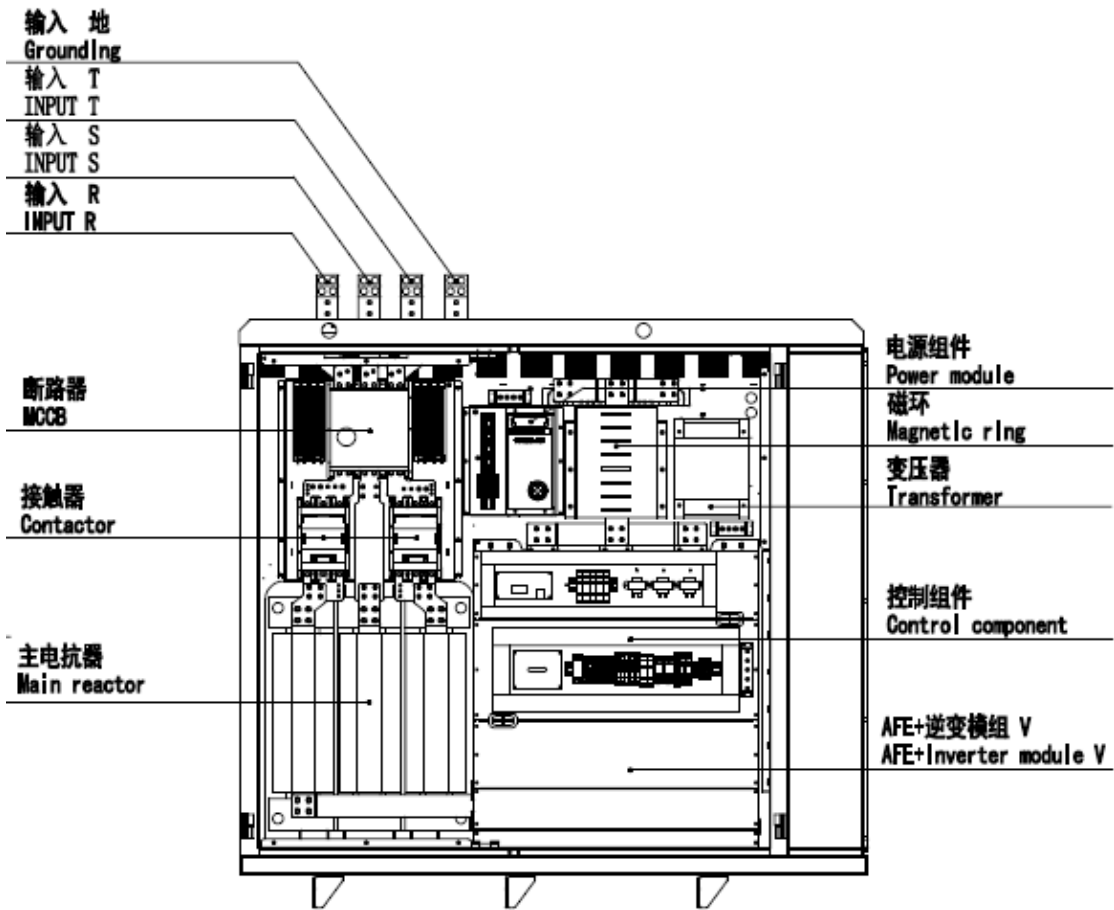

Figure 13: front naked door illustration

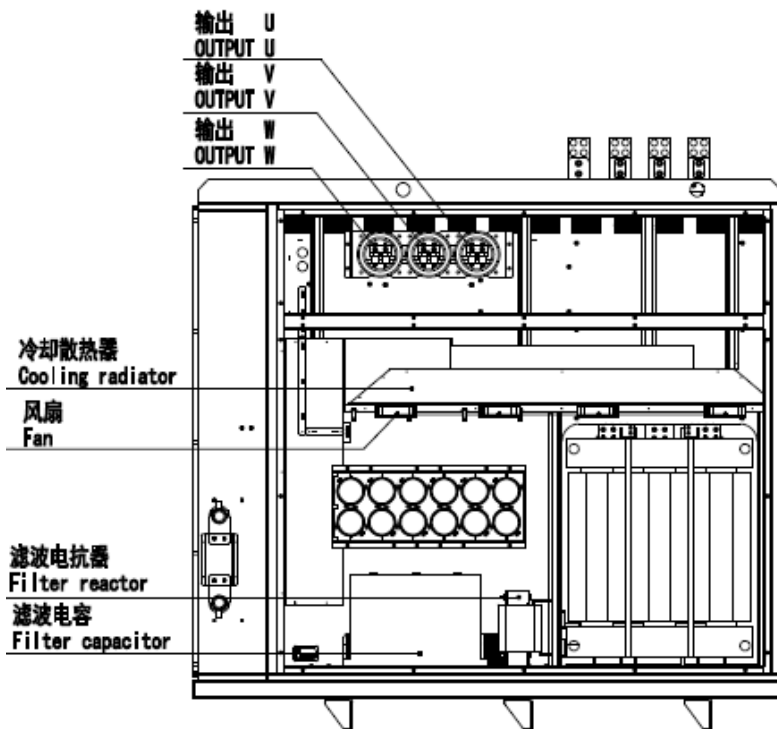

Figure 14: diagram of the rear naked door

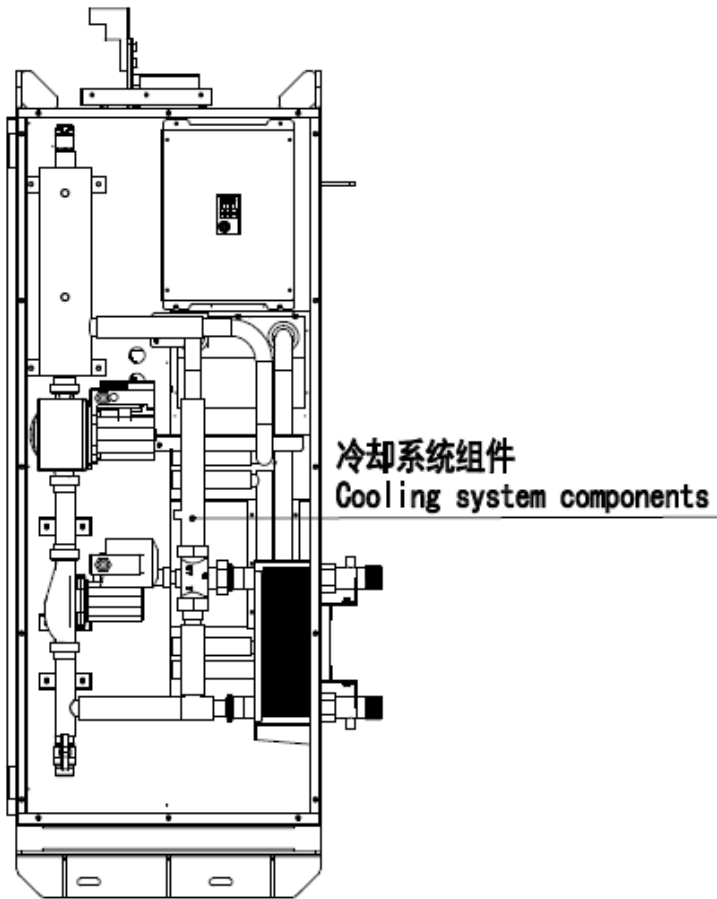

Figure 15: right side cooling components

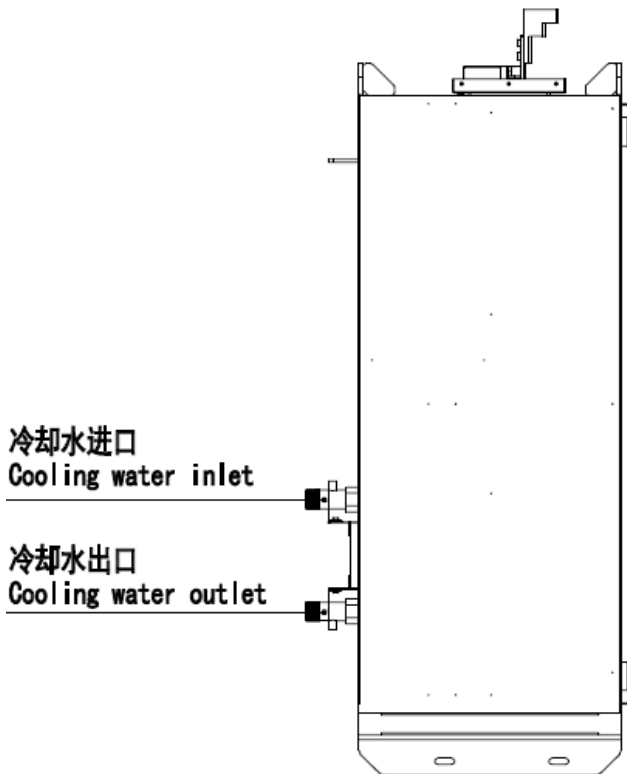

Figure 16: inlet and outlet of cooling water on the left side

### 3.2.3 LG-AFE-991-1386A Model

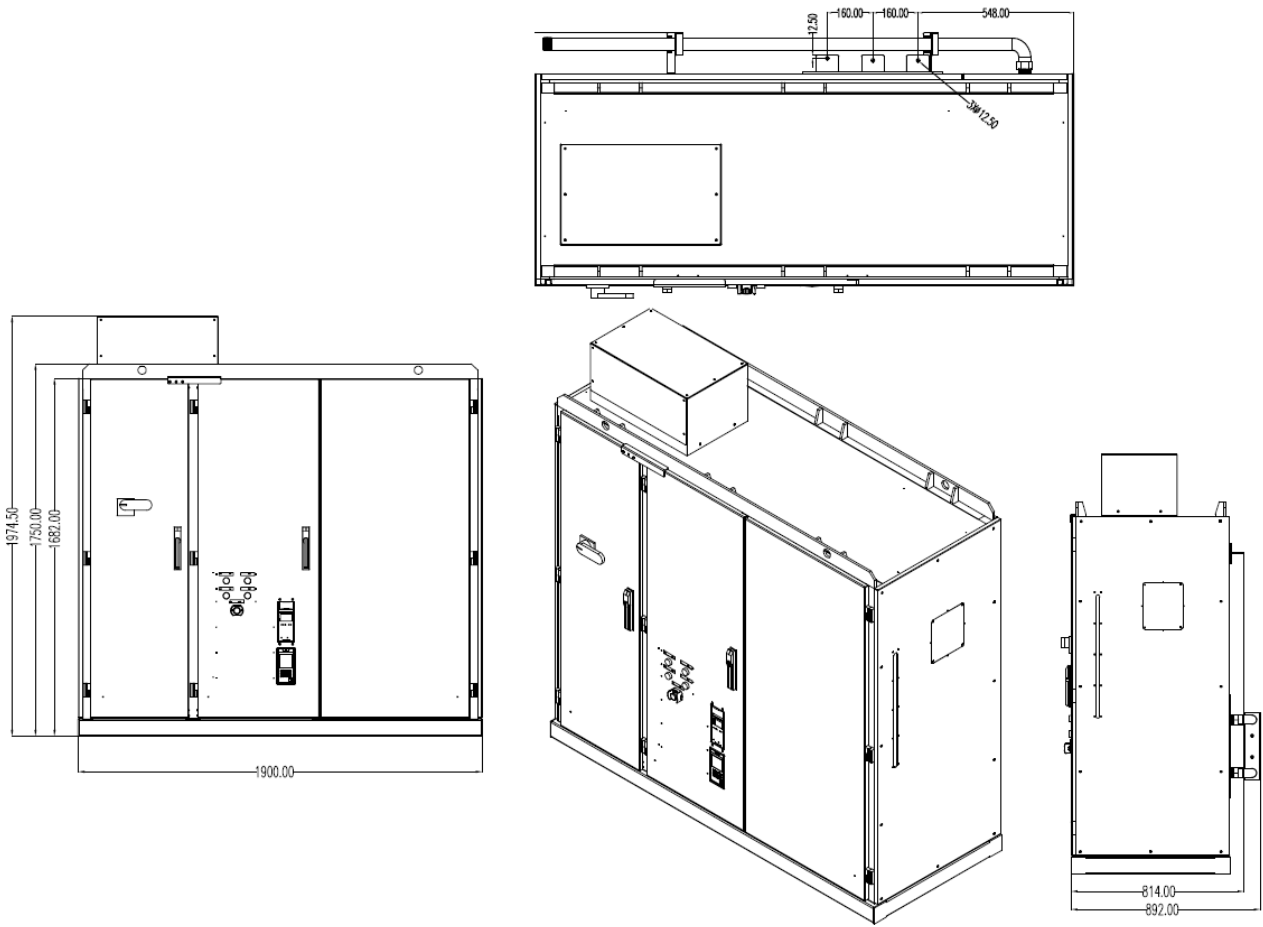

Figure 17: front appearance

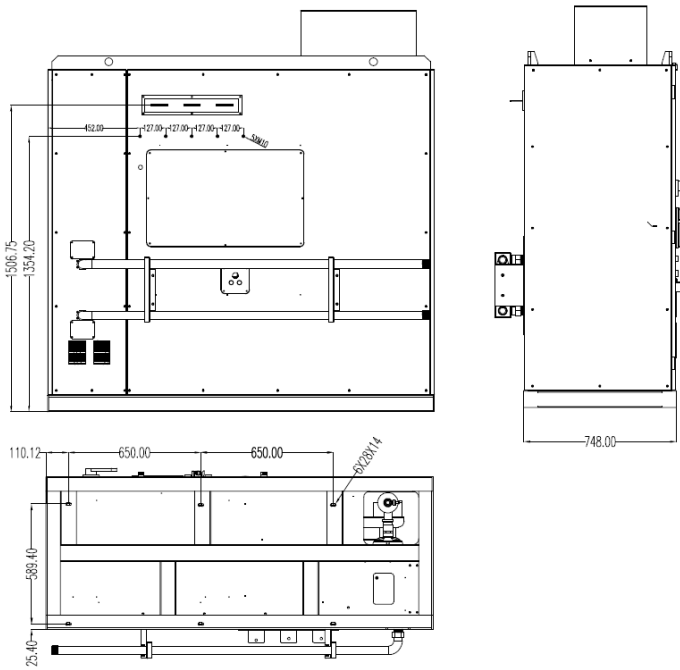

Figure 18: back appearance



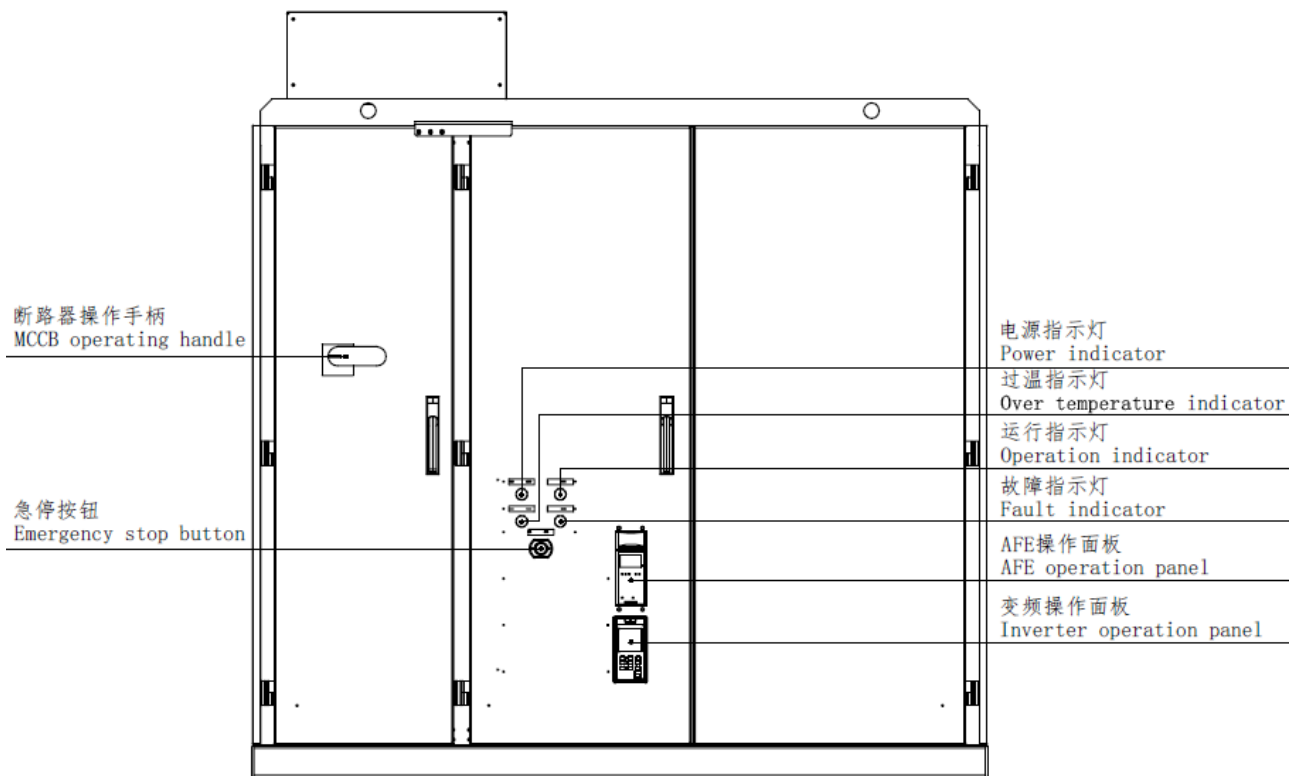

Figure 19: front controls

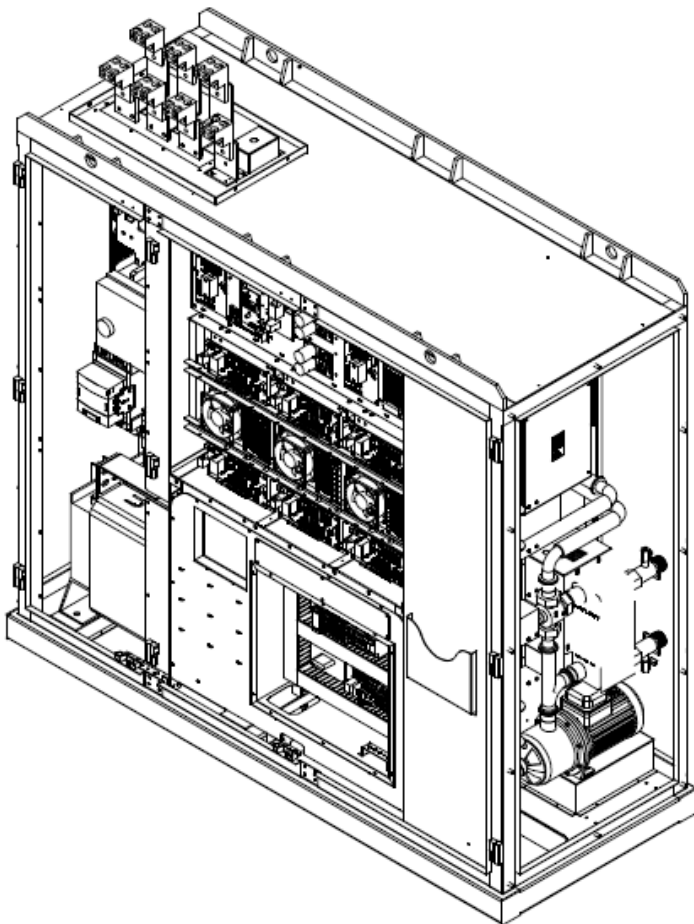

Figure 20: illustration of a side naked door

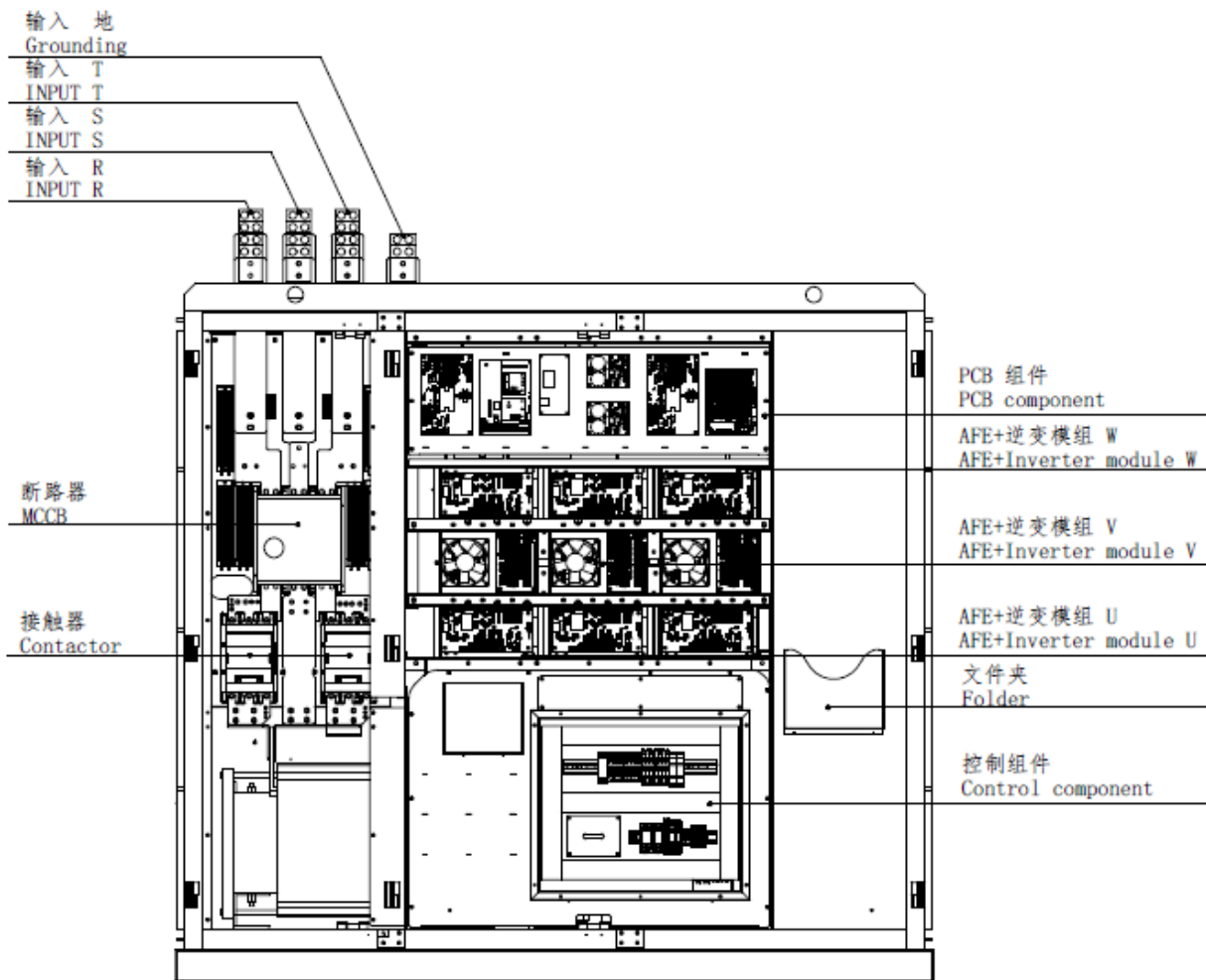

Figure 21: front naked door illustration

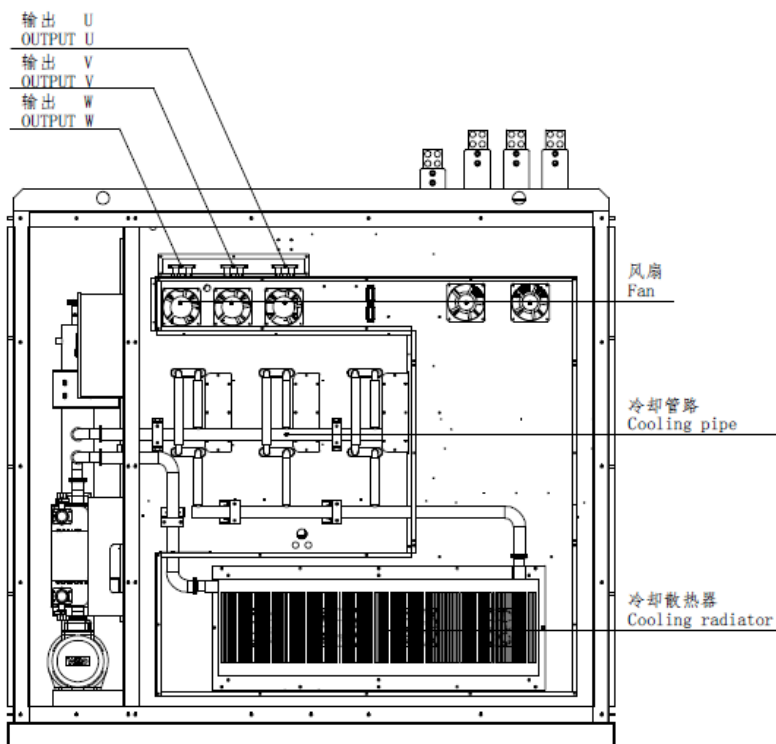

Figure 22: diagram of the rear naked door

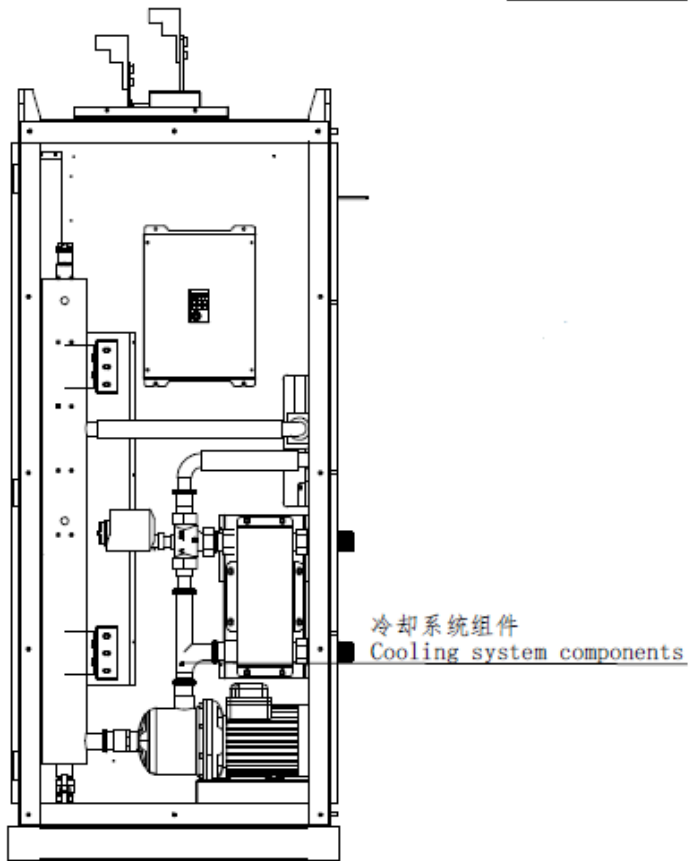

Figure 23: right side cooling components

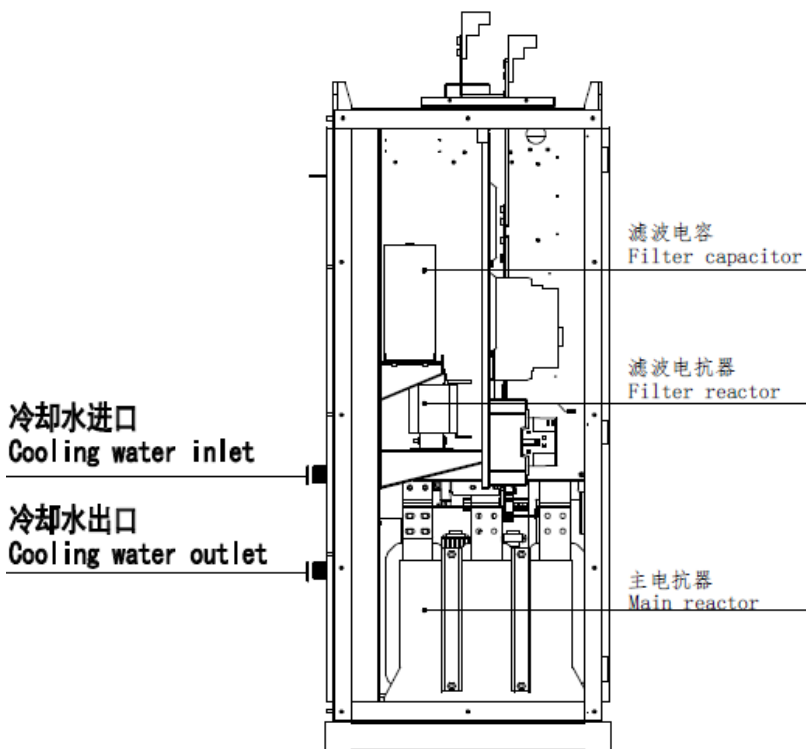

Figure 24: inlet and outlet of cooling water on the left Side

## 3.2.4 Inverter Panel Peripheral Equipment Wiring And

### Attentions

Be sure to confirm the warning message of the front outer cover of the inverter cabinet, as shown in Figure 3.3 below.



Figure 3.3 warning labels



#### Attention

1. Within **15** minutes after the input power is cut off, the main circuit may still have high voltage. The operation can be carried out only after confirming that the DC bus voltage is lower than 36V;
2. Wiring or disassembly of internal connector of inverter cabinet shall not be carried out in power transmission;
3. Never connect the inverter output terminals U, V, W to the AC power supply;
4. The grounding terminal E of the inverter cabinet must be grounded;
5. Please do not test the internal components of the inverter, these semiconductor parts are vulnerable to high pressure and damaged;
6. CMOS integrated circuit board of inverter is vulnerable to electrostatic influence and damage. Do not touch circuit boards.

*Note: The main power switch points to the "OFF" position when the inverter is out of the factory. Do not switch the main power switch to the "ON" position until the connection is completed and check is confirmed.*

## 3.3 Connection Between Machine Sets And Inverter Panel

### 3.3.1 Mainframe Components

1. Suction elbow
2. Compressor
3. Inverter cabinet
4. Control cabinet
5. Condenser
6. Motor shell
7. Economizer
8. Fuel tank
9. Exhaust device
10. Evaporator
11. Display panel
12. Inverter cooling line

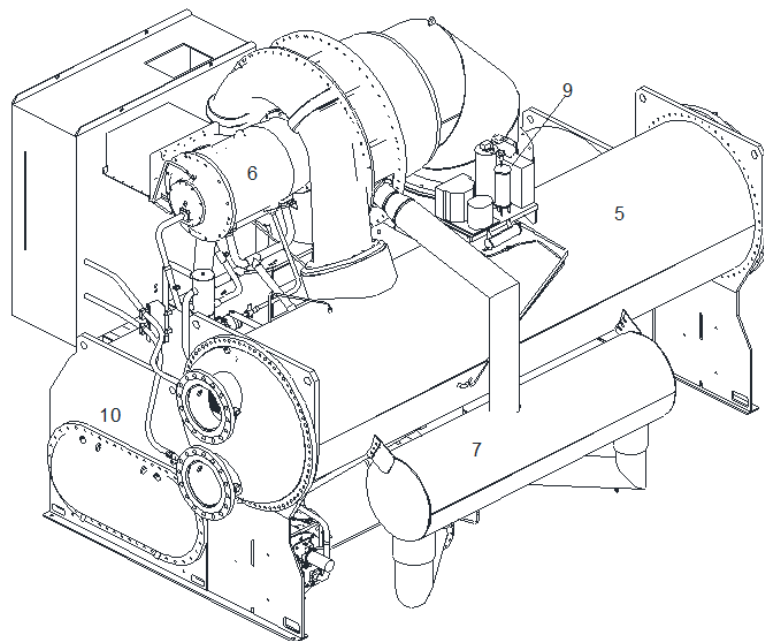
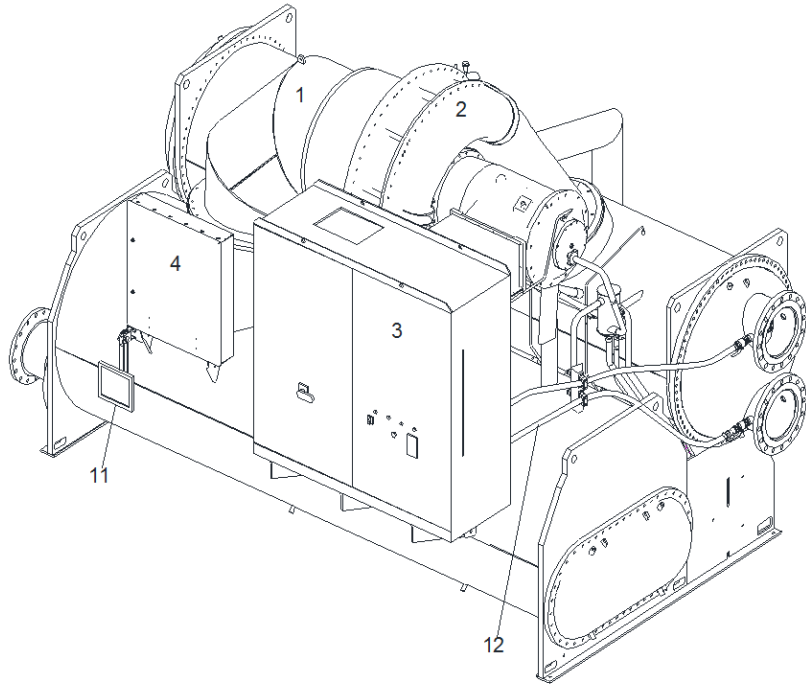

*Figure 3.4.1.2 effect diagram of right side water intake by condenser*

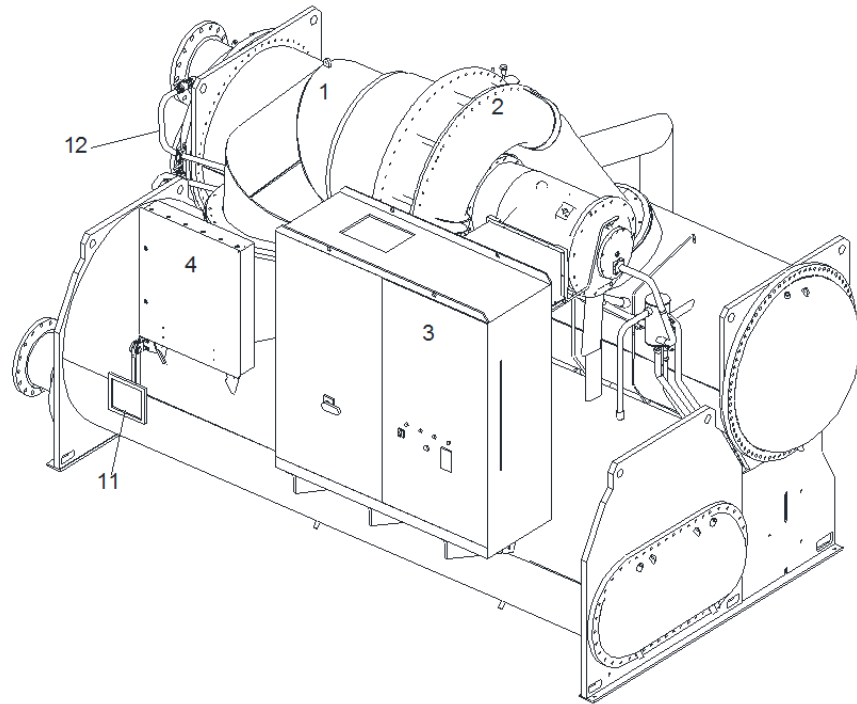

*Figure 3.4.1.3 effect diagram of left side water intake by condenser*

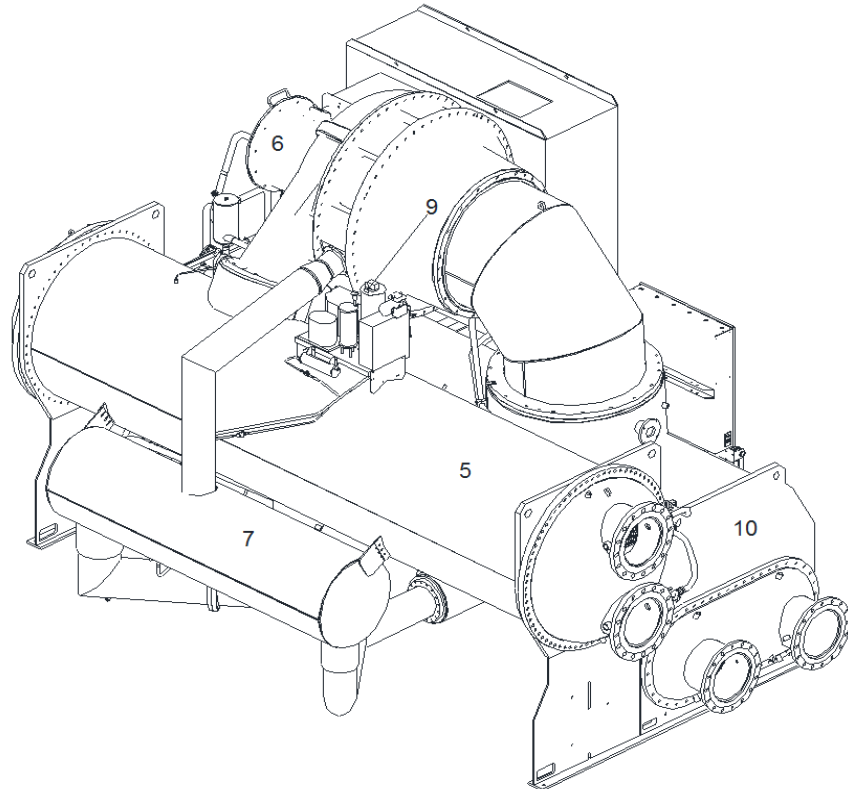

*Figure 3.4.1.4 effect diagram of left side water intake by condenser*

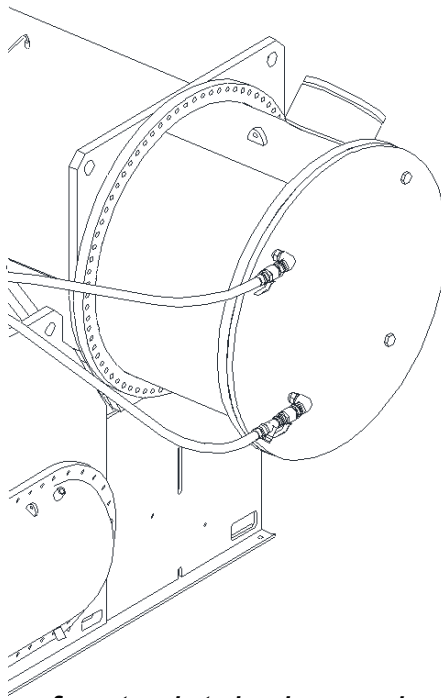
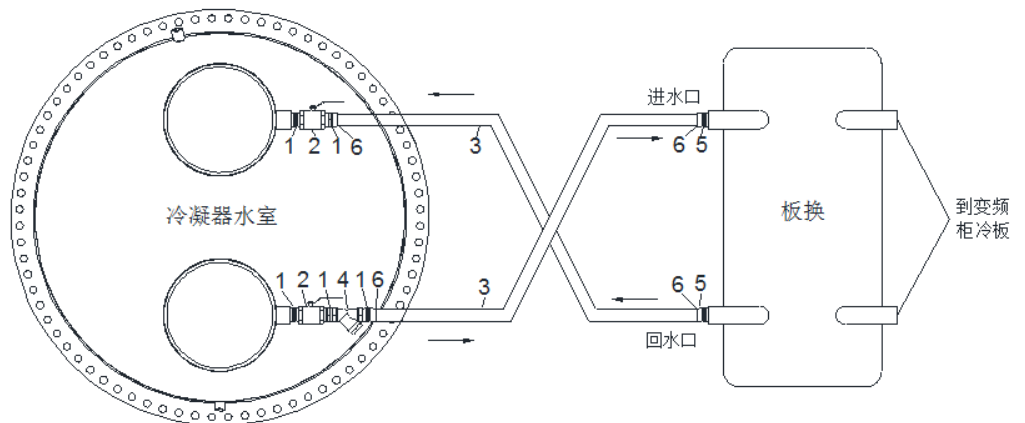

Figure 3.4.1.5 effect diagram of water intake by marine condenser chamber

### 3.3.2 Inverter Panel Cooling Pipeline

- 1. Straight joint
- 2. Ball valves
- 3. High pressure hose
- 4. Y filter
- 5. Straight joint
- 6. Gaskets



Note: two elbows will be added for marine

Figure 3.4.2.1 non-marine cooling pipeline diagram





# Chapter 4 Inverter Panel Operation

## 4.1 Instructions For LCD Panel Of Inverter

### 4.1.1 Keypad Function Instruction

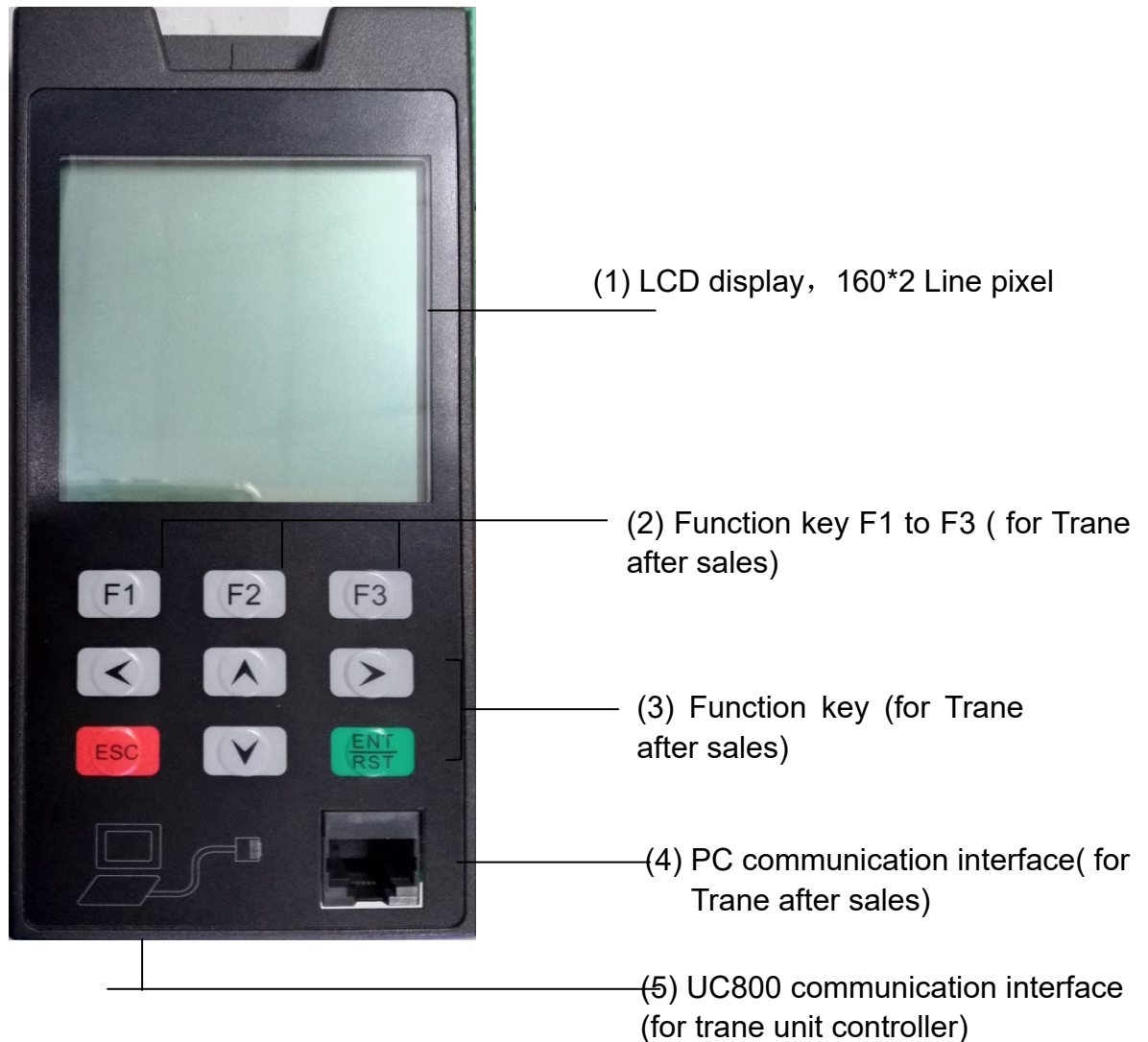

The panel has three function keys (F1, F2, F3) and six operation keys (up, down, left, right, ESC, ENT/RST).

The functions of the operation keys as follows:

1>. The functions of the operation keys

Key	Name	Function
【↑】	Up key	Please click this button when you select the method, group, function, parameter name, setting value (increase), etc.
【↓】	Down key	Please click this button when you select the method, group, function, parameter name, setting value (decrease), etc.
【←】	Left key	Numeric selection key for numeric settings of the

		parameter
<b>【→】</b>	Right key	Numeric selection key for numeric settings of the parameter
<b>【ESC】</b>	Escape key	Skip to parent menu
<b>【ENT/RS T】</b>	Enter key	Press the key when determining the mode, function, parameter, setting value
	Reset key	<b>【F1】</b> When you monitor the alarm at the interface, press this button to reset the fault

## 4.1.2 Main Monitoring Parameters

Parameter No.	Parameter Name
0-0	Drive status
0-1	Given value display
0-2	Ramp output display
0-3	Actual frequency display
0-7	Actual value display
0-11	Write torque display
0-12	Actual torque display
0-15	Actual current
0-16	Actual current peak
0-17	Effective current
0-18	DC Bus Voltage
0-19	Peak DC bus voltage
0-20	Output voltage
0-21	Input terminal status
0-22	Internal input status
0-23	Output condition status
0-24	Output flag bit status
0-25	Output terminal status
0-38	Power module temperature
0-40	Cumulative power-on time
0-81	Effective power
0-87	Excitation current
0-92	Input power
0-93	Power loss

## 4.1.3 Common Parameter Setting Table Of Inverter

Keypad Parameter	Definition	Initial Value
1-00	Frequency given source	1: Analog input AUX
1-01	Rotating source	7: No LS
1-06	Min. speed limit	0 rpm/min
1-10	Max. speed limit	2100 rpm/min

1-14	Min. speed overspeed limit	4000 rpm/min
1-28	Acceleration time	5 sec
1-30	Deceleration time	5 sec
3-06	Velocity circulation ratio	300
3-09	Velocity circulation intergral	100
4-00	Current circulation ratio	1500
4-01	Current circulation intergral	1500
5-11	Carrier frequency	

(plus)

<b>Keypad Parameter</b>	<b>Definition</b>	<b>Initial Value</b>
5-18	Dead time compensation mode	0: off
6-23	Rated current of motor	
6-24	Rated speed of motor	
6-25	Rated frequency of motor	
6-26	Peak value of back EMF of motor at 1000rpm	
6-27	Rated torque of motor	
6-28	Motor zero speed current	
6-30	Resistance between motor wires	
6-31	Inductance between motor wires (d-axis)	
6-34	Motor protection time	8.0 sec
6-48	Static self-learning instruction	0: off
6-50	Motor min. protection Is/Id	150%
6-64	Inductance between lines (q-axis)	
6-67	Self-learning current	
9-02	Max. frequency mode	8
10-01	Parameter initialization	0: no effect
10-10	Determining motor parameters	1
12-00	PNP/NPN selection	0: PNP
12-01	Digital signal source selection	0: no input
12-02	Digital input setting	0: no input
13-02	Condition 2	4: Action in case of fault
13-03	Condition 3	2: Runtime actions
17-09	HSP5 Watchdog Time	0.0 sec
18-61	Apparent current / actual torque PT time	3:8 ms
18-64	Actual value PT1 time	0: off
21-00	Motor model selection	191
21-01	Steady current	

21-02	Min. speed of starting model	
21-03	Max. speed of starting model	
21-05	Filtering time of velocity calculation	1.000 ms
21-07	Modulation factor	2.00%
21-09	Startup time	5.00 sec
21-10	Quiescent current	
21-12	Deviation control time	10.000 ms
21-17	Speed critical point of open-loop cutting model	0.000 rpm/min

#### 4.1.4 Display Instructions

1>.Power on the initial interface, or press [F1] key to enter the monitoring interface

Inverter status - > normal:

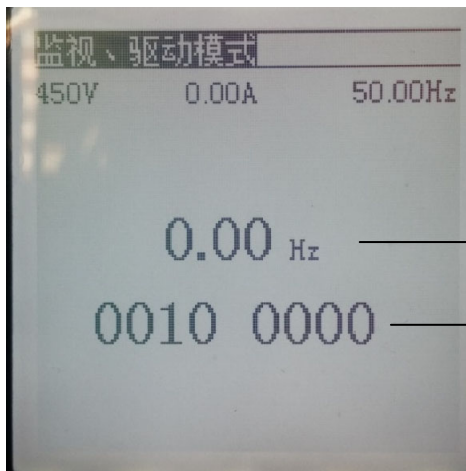

Display line 1, display content from left to right in turn:  
Bus Voltage, Output Current, Frequency Instruction

Display line 2:  
output frequency

Display line 3, bit7 ~ bit0 from left to right:  
Inverter status (see table below)

Inverter status:

bit	Instruction
0	0: stop 1: In operation
1	Not used
2	0: Positive rotation 1: Reverse rotation
3	Not used
4	Not used
5	1: Inverter ready
6	Not used
7	Not used

Inverter status: report an error

Display below the middle of the screen. For example, when the inverter reports low-voltage alarm, the panel screen is shown as follows:

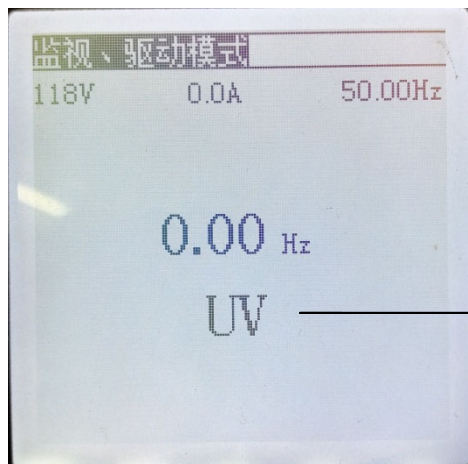

At the present, the inverter is in low-voltage state, and "UV" flashes

## 4.2 Motherboard Terminal Wiring Diagram

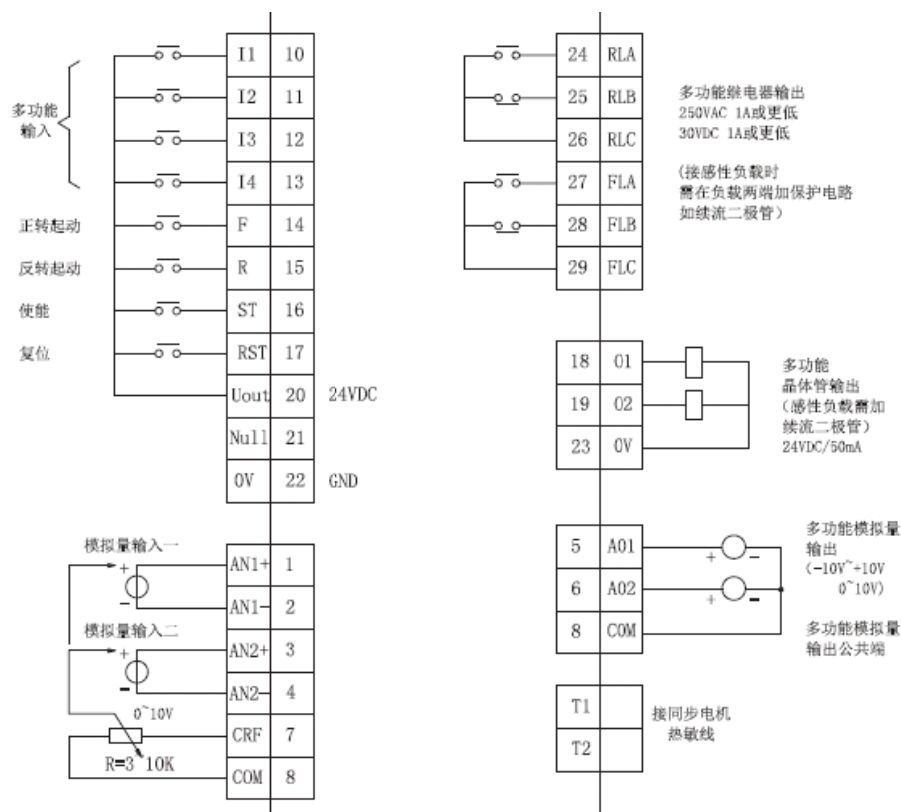

## 4.3 Alarm And Warning

### 4.3.1 Alarm

When the inverter panel gives an alarm, the LCD screen will display the alarm code, and the Trane touch screen will display the specific information of the alarm. The unit will be shut down, such as the inverter panel over-current, over temperature, etc.

For some alarms, when the triggering condition of the alarm disappears, the unit and the inverter panel can reset automatically and run again.

For other alarms, manual reset is required before the unit can be re operated.

Reset Type	Alarm Type	Trane Controller Touch Screen Fault Code	LCD Panel Fault Code	Reset Condition
Automatic reset	Inverter undervoltage	AFD Bus Under Voltage	UV Shutdown undervoltage	Voltage recovery
			UV1 running undervoltage	
	Communication interruption – Inverter panel and Trane controller	AFD Comm Loss: Main Processor	COT	Communication recovery
	Communication interruption – Inverter and hand recorder	AFD Comm Loss: Main Processor	CE1	
	Inverter power off	AFD Comm Loss: Main Processor	无报警代码	Power supply restoration
IGBT or reactor overheat	AFD Inverter Heatsink Over Temp	OH IGBT	Temperature reduced to safe range	
		OH1 电抗器		
Manual reset	Inverter panel overvoltage	AFD Bus Over Voltage	OV	Contactors reset
	Emergency stop (emergency stop switch)	AFD Emergency Stop Fault	ES	Emergency stop switch reset
	Emergency stop (high pressure switch)		HPC	High voltage switch reset hand recorder reset

	Emergency stop IGBT Power supply interruption / no load		OE	IGBT power supply recovery hand recorder reset
	Instantaneous overcurrent of inverter	AFD Instantaneous Current Overload	OC	Manual reset of hand recorder
	Short circuit to ground	AFD Ground Fault	GF	
	Motor overcurrent	AFD Motor Current Overload	OL1	
	Output missing phase	AFD Output Phase Loss	LF	
	Other errors of inverter	AFD General Failure	There are multiple codes corresponding to different alarm conditions of inverter	

### 4.3.2 Warning

When the warning occurs, the inverter panel or LCD screen will inform the user that there may be abnormalities in the operation of the inverter, and the customer is recommended to carry out corresponding inspection.

Warning Type	Warning Sign	Warning Reset Method	Check Position After Warning
IGBT or reactor close to the over temperature point	Lighten the yellow warning light	Power off reset (temperature drop and hand recorder reset are invalid)	Reactor and IGBT temperature ((on LCD display)) <ul style="list-style-type: none"> <li>▪ IGBT: output current and water flow of plate heat exchanger (filter net)</li> <li>▪ Reactor: fan air volume</li> </ul>
Inverter and UC800 communication	CO_NG Inverter panel LCD	Communication returns to normal	Wiring between inverter LCD display and Trane unit controller Internal

quality is not good	screen		communication wiring of inverter (or after-sales inspection with Trane)
Communication failure between hand recorder and power meter	COT1 Inverter panel LCD screen	Communication returns to normal	Wiring between inverter LCD display and Trane unit controller Internal communication wiring of inverter (or after-sales inspection with Trane)



# Chapter 5 AFE Panel Operation

## 5.1 AFE LCD Panel Usage Instruction

### 5.1.1 Panel Function Instruction



(1) LCD display, 160\*2 Line pixel

(2) LED Indicator, 5 Status  
DRIVE、 FWD、 REV、 SEQ、 REF

(3) Function key, 9 Options  
Menu、 Δ、 LOCAL/REMOTE  
ESC、 READ/WRITE、 /RESET  
FWD/REV、 ▽、 JOG  
Menu、 Δ、 LOCAL/REMOTE

(4) The operation keys  
RUN  
STOP

### 5.1.2 Keypad Definition

键	文章中的名称	功能
	LOCAL/REMOTE (运行方法选择)	切换用数字操作器控制运行 (LOCAL) 和控制回路端子控制运行 (REMOTE) 时, 请按此键。
	MENU (菜单)	表示各种方式。
	ESC (退回)	按一 ESC 键, 则回到前一个状态。
	JOG (点动)	在操作器运行场合的点动运行键。
	FWD/REV (正转/反转)	在操作器运行场合, 切换旋转方向键。
	RESET (复位)	参数的数值设定时的数位选择键。 故障发生时作为故障复位键使用。
	增加键	选择方式, 组, 功能, 参数的名称, 设定值 (增加) 等时请按此键。
	减少键	选择方式, 组, 功能, 参数的名称, 设定值 (减少) 等时请按此键。
	DATA/ENTER (数据/输入)	决定各方式, 功能, 参数, 设定值时, 按下。
	RUN (运行键)	用操作器运行时, 按下此键变频器开始运行。
	STOP (停止键)	用操作器运行场合时, 按下此键, 变频器便停止。 用控制回路端子运行的场合根据参数 (c02-02) 的设定可设定该键的有效/无效。

### 5.1.3 AFE Switching Mode

AFE Panel has 5 modes, as follows:

方式名称	主要内容
驱动方式	变频器运行可能的方式。 频率指令，输出电流等的监视，异常内容显示，异常记录显示等。
环境设定方式	操作器显示语种选择，参数的读取，设定级别（存取级别）的设定。 控制方式的选择，参数的初始化等。
编程方式	运行所必要的参数的读取，设定编程方式，按功能群有如下划分。 <ul style="list-style-type: none"> <li>• 应用：选择运行方式，直流制动，速度搜索等</li> <li>• 调整：加减速时间，S字特性，载波频率等</li> <li>• 指令关系：有关频率指令设定</li> <li>• 电机参数：V/f特性，电机参数</li> <li>• 选项参数：关于选择卡的设定</li> <li>• 外部端子功能：关于程序器（PLC）输入输出，模拟量输入输出的设定</li> <li>• 操作器：操作器的表示功能，键功能的选择</li> </ul>
自学习方式*	使用不知道电机参数的电机，且用矢量控制方式进行运行的场合，电机参数可自动地被计算并设定。
检验方式	进行与出厂时设定的不同参数读取设定。

### 5.1.4 Mode Switching Way

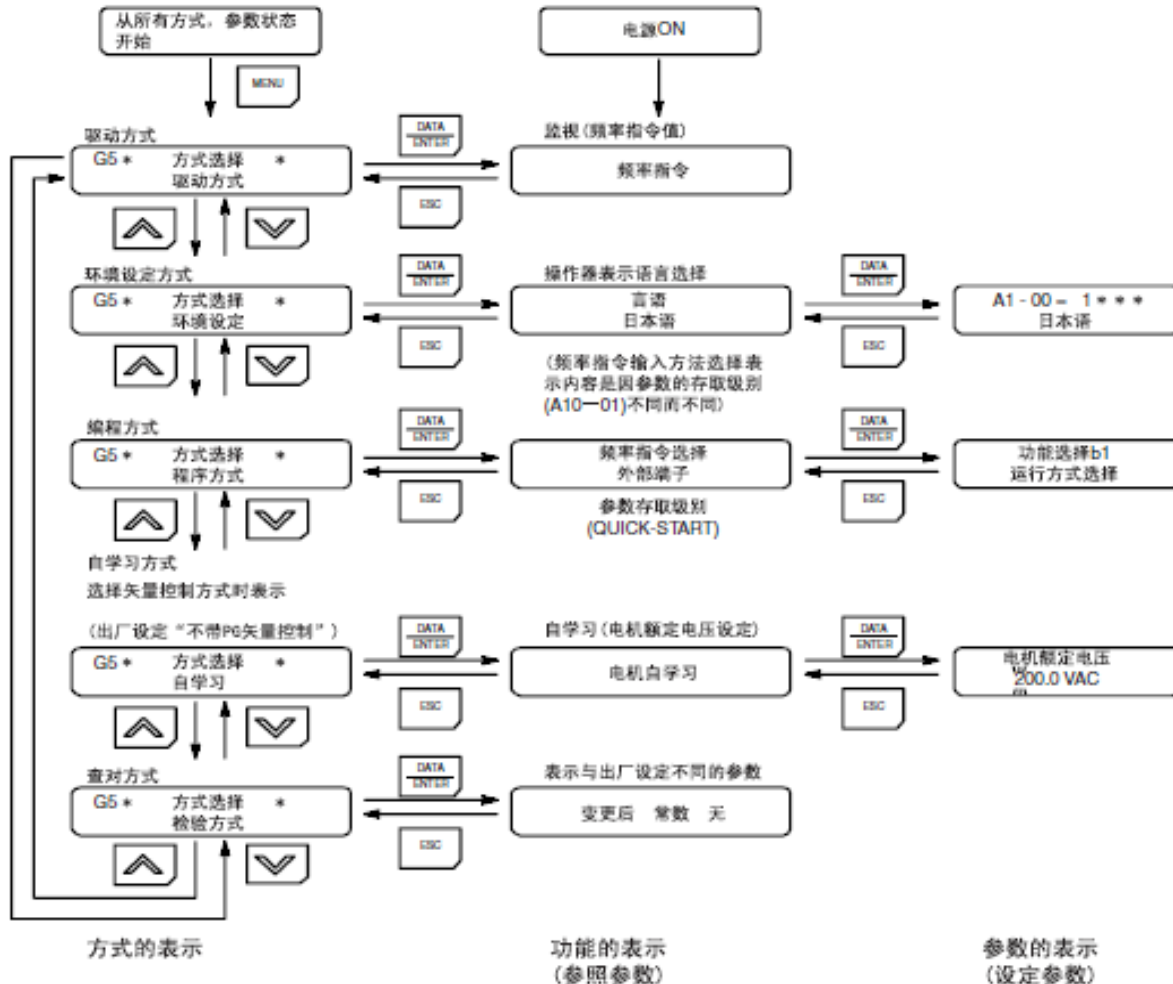

## 5.1.5 The Process Of Modifying Parameter Values Is As Follows

Example: modify parameter, C1-01 (acceleration time)

C1-01 changed from 10.0 seconds to 20.0 seconds

顺序	键	操作器的表示画面	说明
1	MENU	* Main Menu Operation *	
2	↑ 按2次	* Main Menu Programming *	
3	DATA ENTER	Group b Application	
4	↑	Group C Tuning	
5	DATA ENTER	Function C1 Accel/Decel	已达到了功能表示（参数参照）的阶层
6	DATA ENTER	Accel Time1 C1-01= 10.0 Sec	
7	DATA ENTER	Accel Time1 0010.0Sec	最左位的“0”闪烁，可以变更在闪烁中的位的数字
8	RESET 按2次	Accel Time1 0010.0Sec	闪烁的位向右移了2位。
9	↑	Accel Time1 0020.0Sec	从1变更为2，已设定好了。
10	DATA ENTER	Entry Accepted	设定值 20.0Sec 已写入了。
		Accel Time1 C1-01= 20.0 Sec	数秒钟后，操作器的表示画面自动地如左所示。
11	ESC	Function C1 Accel/Decel	

At this time, the acceleration time c1-01 has been changed from 10.0 seconds to 20.0 seconds

## 5.1.6 Main Monitoring Parameters

Parameter No.	Parameter Name	Unit	Access Level	Notes
U1-01	Output voltage instruction	1V	Q	
U1-02	Output voltage feedback	1V	Q	
U1-03	The output current	1A	Q	
U1-04	The input voltage	1V	Q	
U1-05	The input current	1A	Q	
U1-06	The output power	1KW	Q	
U1-07	The input power	1KW	Q	

(plus)

Parameter No.	Parameter Name	Unit	Access Level	Notes
U1-08	Input frequency	0.01Hz	Q	
U1-10	Input terminal status	-	Q	
U1-11	Output terminal status	-	Q	
U1-12	RUN state	-	Q	
U1-13	Running time	1H	Q	
U1-14	Read only memory (FLASH)	-	Q	
U1-18	Active current component (Iq)	0.1%	Q	
U1-19	Reactive current component (Id)	0.1%	Q	
U1-20	Output reference voltage (post-SFS)	1V	A	
U1-21	AVR (automatic voltage regulation) Input (voltage deviation)	1V	A	
U1-22	AVR (automatic voltage regulation) output	0.01%	A	
U1-26	Output voltage reference (Vq)	1V	A	
U1-27	Output voltage reference (Vd)	1V	A	
U1-28	CPU ID	-	A	
U1-29	LED Check (diagnosis)	-	A	
U1-48	ACRq output	0.1%	A	
U1-49	ACRd output	0.1%	A	
U2-01	Current alarm	-	Q	
U2-02	Last alarm	-	Q	
U2-03	AlarmingU1-01	1V	Q	
U2-04	AlarmingU1-02	1V	Q	
U2-05	AlarmingU1-03	1A	Q	
U2-06	AlarmingU1-04	-	Q	
U2-07	AlarmingU1-05	1A	Q	
U2-08	AlarmingU1-06	1Kw	Q	
U2-09	AlarmingU1-07	1Kw	Q	
U2-10	AlarmingU1-08	0.01Hz	Q	
U2-12	AlarmingU1-10	-	Q	
U2-13	AlarmingU1-11	-	Q	
U2-14	AlarmingU1-12	-	Q	
U2-15	AlarmingU1-13	1H	A	
U2-17	AlarmingU1-18	0.1%	Q	
U2-18	AlarmingU1-19	0.1%	Q	
U2-19	AlarmingU1-20	1V	Q	
U2-20	AlarmingU1-21	1V	A	
U2-21	AlarmingU1-26	1V	A	

U2-22	AlarmingU1-27	1V	A	
U3-01	Last alarm	-	Q	
U3-02	Alarm message 2	-	Q	

(plus)

Parameter No.	Parameter Name	Unit	Access Level	Notes
U3-03	Alarm message 3	-	Q	
U3-04	Alarm message 4	-	Q	
U3-05	Last alarm time	1H	Q	
U3-06	Second alarm time	1H	Q	
U3-07	Third alarm time	1H	Q	
U3-08	The fourth alarm time	1H	Q	

### 5.1.7 Default Setting Of Parameter Table Under Different Models

Parameter No.	Parameter Name	Initial Value	Setting range	Changes yes or not	Access Level	Notes
A1-01	Access level	2	0~9999	Y	Q	0: special for monitoring 2: Quick setting 3: Basic settings 4: Advanced settings
A1-03	Initialization	0000	0000~9999	N	Q	2220: Parameter initialization
A1-04	Password 1 (for input)	0000	0000~9999	N	Q	
B1-01	Reference voltage selection	0	0	N	Q	0: Digital operator
B1-02	Run command selection	1	0/1	N	Q	0: Digital operator 1: External terminal
B1-06	Secondary reading sequence	1	0/1	N	A	0: 1ms Read two times 1: 5ms Read two times
C1-01	Acceleration time	10.0	0.0~6000.0	Y	Q	
C1-02	Deceleration time	10.0	0.0~6000.0	Y	Q	
C5-01	AVR	20.00	1.00~300	Y	B	

	proportional gain					
C5-02	AVR integration time	0.500	0.000~10.000	Y	B	
C5-03	AVR delay time	0.000	0.000~0.500	N	B	
D1-01	Definition of reference voltage		600V~680V	Y	Q	600V~680V (400V level) 750V~900V (600V level)
F1-10	Input frequency deviation	3.0	0.0~10S	N	A	
F1-11	Input frequency deviation detection time	70ms	0~255ms	N	A	

(plus)

Parameter No.	Parameter Name	Initial Value	Setting range	Changes yes or not	Access Level	Notes
H1-01	3 terminal function selection (multi-function input)	24	00~FF	N	B	24: External fault
H1-02	4 terminal function selection (multi-function input)	14	00~FF	N	B	14: Fault reset
H1-03	5 terminal function selection (multi-function input)	0F	00~FF	N	B	0F: not used
H1-04	6 terminal function selection (multi-function input)	0F	00~FF	N	B	0F: not used
H1-05	7 terminal function selection (multi-function	0F	00~FF	N	B	0F: not used

	input))					
H1-06	8 terminal function selection (multi-function input)	08	00~FF	N	B	08: External Base blockade
H2-01	9-10 Terminal selection (multi-function output)	00	00~FF	N	B	00: in operation
H2-02	25 Terminal selection (multi-function output)	06	00~FF	N	B	06: Converter read
H2-03	26 Terminal selection (multi-function output)	0A	00~FF	N	B	0A: MCON period
L1-02	Output OL (OL2) operation	60.0S	1.0~120.0S	N	B	Refer to user manual Generally no need to change
L1-03	Output OL (OL2) detection	110%	50~200%	N	B	
L1-04	Output OL (OL2) Action selection	1	0/1	N	B	0: keep on running 1: BB stop
L2-01	Action selection in case of instantaneous power failure	0	0~2	N	B	
L2-02	Compensation time of instantaneous power failure	1.0	0.0~2.0S	N	B	
L2-05	Low voltage detection value	380	300~420V	Y	A	660V voltage X 1.5 setting
L3-02	Input OL (OL1) Action time	60.0	1.0~120.0S	N	-	
L3-03	Input OL (OL1) Action time	110%	50~200%	N	-	
L3-04	Input OL (OL1) Action selection	1	0/1	N	B	0: keep on running 1: BB stop

						(Base blockade stop)
L5-01	Failure retry times	0	0~10	N	B	
L5-02	Action selection of fault output contact in fault retry	0	0/1	N	B	0: no action 1: action

(plus)

Parameter No.	Parameter Name	Initial Value	Setting range	Changes yes or not	Access Level	Notes
L7-01	Drive side torque limit	150%	0~300%	N	B	
L7-02	Regeneration side torque limit	150%	0~300%	N	B	
L8-02	OH (overheat) alarm value	95	50~110℃	N	A	
L8-03	OH (overheat) alarm action selection	3	1, 3	N	B	1: BB stop (Base blockade stop) 3: keep on running
O1-01	Selection of items displayed in monitoring mode	8	4~50	Y	B	
O1-02	Selection of monitoring items during power on	1	1~4	Y	B	1: Output voltage instruction (U1-01) 2: Output voltage feedback (U1-02) 3: Output current (U-03) 4: Items selected in O1-01
O2-01	LOCAL/REMOTE Key selection	1	0/1	N	B	0: Forbidden 1: Enable
O2-02	Stop Key enable selection	0	0/1	N	B	0: The RUN command is valid when it is operated by a digital operator 1: Always effective
O2-04	KVA selection	*	00~FF	N	B	Factory set



						complete
O2-06	Disable / enable selection when digital operator is interrupted	0	0/1	N	A	0: Continue to run when the digital operator is disconnected 1: inverter panel error when digital operator connection is interrupted
O2-07	Running time setting	-	0~65535H	N	A	
O2-08	Running time selection	0	0/1	N	A	0: According to power on time 1: According running time

### 5.1.8 Indicator Light Of Operation And Stop Key

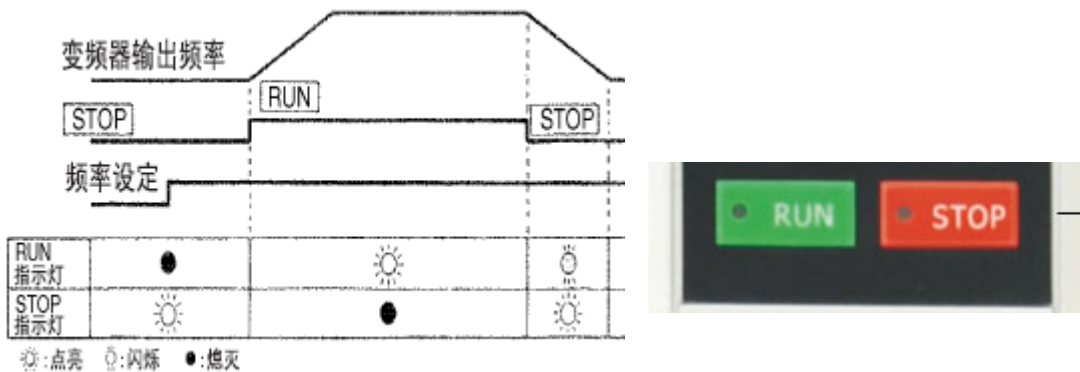

### 5.1.9 Indicator Light Of Operation And Stop Key

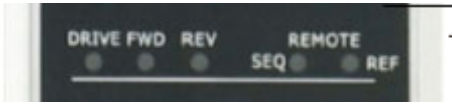

## Operation Mode Indicators

- DRIVE: Lit when in operation mode.
- FWD: Lit when there is a forward reference input.
- REV: Lit when there is a reverse reference input.
- SEQ: Lit when an operation reference from the control circuit terminal is enabled.
- REF: Lit when the frequency reference from control circuit terminals 13 and 14 is enabled.

## 5.2 Mainboard Terminal Wiring Diagram

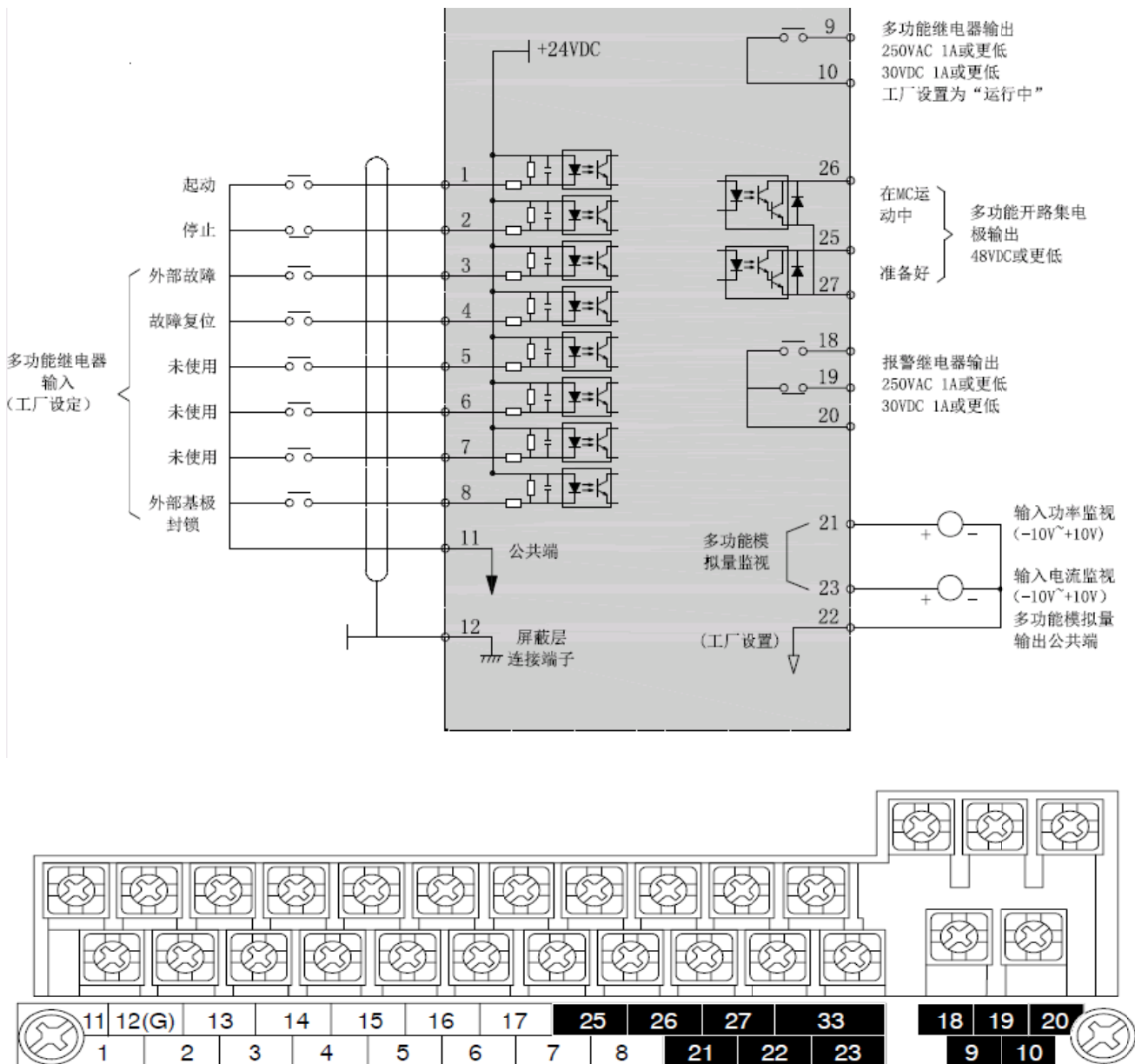

# Chapter 6 Abnormal Diagnosis And Troubleshooting

## 6.1 Inverter Panel General Rules

Inverter cabinet fault detection and early warning / self-diagnosis function. When the inverter detects a fault, the code is displayed on the LCD operator. The output of the fail contact is acting, the inverter output is cut off, and the motor is free to stop (in some areas of failure, the method of shutdown is optional.).

When the inverter detects a warning, the LCD will display the warning code, the fault output contact does not act, once this warning is lifted, the system will automatically restore the original state.

The inverter has three levels of error message display, as follows:

Item	Level	Reaction of Inverter Panel	Supplement
1	Inverter status (Status)	Inverter does not stop, display status code	
2	Inverter warning alarm (Warning)	Inverter does not stop, warning code flashing	Yellow grade
3	Inverter fault alarm (Fault)	Inverter stop, fault code flashing	Red grade

The following faults may occur during the use of the inverter. Please refer to the following methods for simple fault analysis:

No.	Fault Phenomenons	Reasons	Solutions
1	No display when powered on	1. No power grid voltage or it's too low 2. Switch power occurs fault on the drive board of inverter 3. The rectifier bridge is damaged 4. Buffer resistance of inverter is damaged 5. Failure of control board and keyboard 6. The connection line between the control board, drive board and keyboard is broken	1. Check the input power 2. Check bus voltage 3. Reset the hand controller 4~6. Seeking Manufacturer's Service

No.	Fault Phenomenons	Reasons	Solutions
2	The motor does not rotate after inverter runs	<ol style="list-style-type: none"> <li>1. Motor and motor wire</li> <li>2. Inverter parameter setting error (motor parameter)</li> <li>3. Poor contact between drive board and control board</li> <li>4. Drive Board Fault</li> </ol>	<ol style="list-style-type: none"> <li>1. Reconfirmation of the connection between the inverter and the motor</li> <li>2. Replacement of motors or removal of mechanical faults</li> <li>3. Check and reset motor parameters</li> <li>4. Seeking Manufacturer's Service</li> </ol>
3	Input terminal failure	<ol style="list-style-type: none"> <li>1. Parameter setting error</li> <li>2. External signal error</li> <li>3. Control panel fault</li> </ol>	<ol style="list-style-type: none"> <li>1. Check and reset H1 group related parameters</li> <li>2. Re-connect the external signal line</li> <li>3. Seeking Manufacturer's Service</li> </ol>
4	Inverters frequently report overcurrent and overvoltage faults	<ol style="list-style-type: none"> <li>1. The motor parameters are set incorrectly</li> <li>2. Improper acceleration and deceleration time</li> <li>3. Load fluctuation</li> </ol>	<ol style="list-style-type: none"> <li>1. Resetting motor parameters or tuning motor</li> <li>2. Setting the appropriate acceleration and deceleration time</li> <li>3. Seeking Manufacturer's Service</li> </ol>
5	Power (or operation) report UV3	<ol style="list-style-type: none"> <li>1. Soft start contactor does not connect</li> </ol>	<ol style="list-style-type: none"> <li>1. Check whether the contactor cable is loose</li> <li>2. Check whether the contactor has faults</li> <li>3. Check whether the 24V power supply of contactor has faults</li> <li>4. Seeking Manufacturer's Service</li> </ol>
6	Compressor doesn't rotate	<ol style="list-style-type: none"> <li>1. Failure of startup signal or frequency</li> <li>2. Low frequency torque boost is too small</li> </ol>	<ol style="list-style-type: none"> <li>1. Check signal given</li> <li>2. Increase low frequency torque</li> </ol>
7	Compressor reversal	Inconsistent Phase Sequence between Motor and Frequency Converter	<ol style="list-style-type: none"> <li>1. Change wiring between motor and inverter</li> </ol>
8	Low compressor speed	UC800 frequency communication command given too low	<ol style="list-style-type: none"> <li>1. Check UC800 given frequency</li> </ol>
9	The compressor can not reach the max. speed	The max. frequency and upper limited frequency of UC800 are set low	<ol style="list-style-type: none"> <li>1. Increase the max. frequency of UC800</li> </ol>
10	The compressor	Motor parameters are not set correctly	<ol style="list-style-type: none"> <li>1. Set parameters according to motor nameplate</li> </ol>

No.	Fault Phenomenons	Reasons	Solutions
	speed is not stable		
11	The unbalanced three-phase input current of the main power supply exceeds 3%	1. The power supply of power grid is provided by transformer, and the voltage is unbalanced 2. Reactor is abnormal	1. Check whether the power grid is balanced; 2. Check whether the reactor is damaged

## 6.2 Status Information

Status information cannot be superimposed. The status information shows the current operation status of the converter (such as forward constant operation, pause status, etc.).

The description of the display information and its reasons is as follows:

Display	Information	Definition
<b>bbI</b>	Modulation blockade	Holding brake function, holding brake closed
<b>bon</b>	Brake closure	Holding brake function, holding brake closed
<b>boFF</b>	Brake release	Holding brake function, holding brake release
<b>Cdd</b>	Calculate running	Motor stator resistance measurement
<b>Dcb</b>	DC braking	There is DC bus voltage at the output end to slow down the motor
<b>dLS</b>	Low speed / DC braking	Module closed after DC braking
<b>FAcc</b>	Forward acceleration	Accelerate rotation clockwise by setting slope time
<b>Fcon</b>	Forward constant	Accelerate/decelerate and operate clockwise at constant speed/frequency
<b>FdEc</b>	Forward deceleration	Stop clockwise rotation by setting slope time
<b>HCL</b>	Hardware current limit	When the output current reaches the hardware current limit, this information is output.
<b>IdAtA</b>	Invalid data	The parameter address set for this parameter value is invalid.
<b>LAS</b>	LA stop	This information is displayed when the load is limited to the preset load

		level during the acceleration process.
<b>lds</b>	LD stop	This information is displayed when the load is limited to the preset load level or when the DC bus voltage is limited to the preset voltage level in the acceleration process.
<b>LS</b>	low speed	There is no preset direction of operation and the module is closed.
<b>nO_PU</b>	Power unit not ready	The power unit is not ready or identified by the controller.
<b>nop</b>	No operation	Control enablement is not open (terminal ST).
<b>PA</b>	Location	Display this information during positioning.
<b>PLS</b>	Low Speed/Power Switch	No modulation when the power supply is disconnected
<b>PnA</b>	Could not reach the designated position	The designated position cannot be reached in the preset slope. Location abort is programmable.
<b>POFF</b>	Power-off protection	According to the function programming design, after the system restores to normal state or reset, the inverter automatically restarts.
<b>POSI</b>	location	Location function is turned on.
<b>rAcc</b>	Reverse acceleration	Accelerate the operation counter-clockwise by setting the slope time.
<b>rcon</b>	Reverse Constancy	Acceleration/deceleration is completed and rotated counterclockwise at constant speed/frequency.
<b>rdEc</b>	Reverse deceleration	Stop counterclockwise rotation by setting the slope time.
<b>rFP</b>	Ready for positioning	The driving signal indicates that the positioning processing is ready.
<b>SLL</b>	Stall	Displays this information if the load is limited below the setting current limit during constant operation.
<b>SrA</b>	Start Reference Search	Start the search reference point.
<b>SSF</b>	Speed Search	Start speed search function, inverter searches motor speed, and synchronous follow.
<b>StOP</b>	A quick stop	As a response to early warning signals, the fast stop function can be turned on. This information will then be displayed.

## 6.3 Fault Alarm (Fault) Detection Function - 【Inverter Shutdown】

When failure occurs, refer to the table 6.1 for possible reasons and take appropriate

measures. The error message causes the module to stop running immediately. Restart after reset.

When restarting, press the Reset button on the LCD operator. When a fault occurs, the fault message is stored in the fault information (group parameters 93-xx).

**Table 6.1 Warning / Self-Diagnosis And Corrective Actions**

LCD Display	Instructions	Reasons	Corrective Actions
<b>E. Cdd</b>	Error Calculate running Data	<ul style="list-style-type: none"> <li>• If it appears during the open-loop self-learning, check whether the motor parameter input is wrong or whether the relay between the frequency converter and the motor is closed</li> <li>• In addition, this error will occur when the inverter is started when the pole detection function is turned on but the step current setting is low.</li> </ul>	During self-learning, check whether the motor has no load and ensure that the connection between the inverter and the motor is normal
<b>E. dOH</b>	ERROR overheat running	There is no short connection between terminal T1 and terminal T2	Connect terminals T1 and T2 with wires
<b>E.OC</b>	Over current: The output current of the converter exceeds the over-current detection value by about 200% of the rated current. The output or load of the inverter is short circuited	<ul style="list-style-type: none"> <li>• Acceleration ramp is too short</li> <li>• Load during quick start or stop Too large, continuous current exceeding limit</li> <li>• Output short circuit</li> <li>• Ground fault</li> <li>• The deceleration ramp is too short</li> <li>• motor cable is too long EMC,</li> <li>• Start dc braking at high rated voltage</li> <li>• Improper setting of current loop</li> <li>• High input voltage</li> </ul>	<ul style="list-style-type: none"> <li>• The current loop is not properly set and the proportional gain of the current loop is too large. Try reducing the value by 4-00 or increasing the acceleration time by 1-28</li> <li>• If the overcurrent is reported in the self-learning process, you can check whether the motor parameters are set correctly. The specific method is to do self-learning step by step. Set 6-48 as 1 for self-learning until 6. See which self-learning motor reports overcurrent, that is, the corresponding motor parameters in which step are not set</li> </ul>

			<p>correctly. If it is a synchronous motor, you can appropriately reduce some back EMF (6-26)</p> <p>This is also an effective measure</p> <ul style="list-style-type: none"> <li>• it is also possible that the input voltage is too high, but the possibility is low</li> </ul>
<b>E. OH</b>	Power module overheat	<ul style="list-style-type: none"> <li>• Poor air circulation around the radiator</li> <li>• High ambient temperature</li> <li>• Fan stalled</li> </ul>	<p>Generally, this fault is only for the temperature of the power module. If the temperature value of the power module exceeds the set value, this alarm will be given. At this time, it is necessary to pay attention to whether the frequency converter has been in the working state of overload. If it is better to reduce the use time or load amount, or enhance the heat dissipation function. If this fault is reported in the case of low load, it may be the inverter's false alarm and the inverter's temperature detection Degree of hardware.</p>
<b>E.OH2</b>	Motor Protection	<ul style="list-style-type: none"> <li>• There is no short circuited motor at terminals T1 and T2. This fault is reported during self-learning, which may be caused by incorrect parameter setting and tripping of protection relay</li> </ul>	<p>Check whether T1 and T2 terminals are short circuited</p> <p>If this happens during self-learning, you can try to set the zero speed current as high as 1.2 to 1.4 times of the rated current of the motor, not more than 1.5 times.</p> <p>Check whether the motor data is accurate</p>
<b>E.OH1</b>	Internal overheating	<ul style="list-style-type: none"> <li>• The ambient temperature is too high.</li> <li>• The cooling fan has stopped.</li> <li>• Carrier frequency set too high</li> </ul>	<p>Only when the internal temperature of the converter drops more than 3°C can the fault be reset under the condition of E.h1.</p>



<b>E. OL</b>	Overload L: If the overload exceeds the allowable time (see technical data), this fault will occur.	<ul style="list-style-type: none"> <li>• Poor setting of control parameters (with overshoot)</li> <li>• Mechanical failure or overload operation</li> <li>• Inverter size error</li> <li>• Motor wiring error</li> <li>• Encoder damage</li> </ul>	<ul style="list-style-type: none"> <li>• Check the control mode.</li> <li>• Check the rated current of the motor.</li> <li>• Check the load size and operation cycle time.</li> </ul>
<b>E.OL2</b>	Overload 2: This fault occurs when the static constant current is exceeded (see technical data and overload characteristics)		This fault can only be reset in E.nol2 state after cooling time.
<b>E. OP</b>	Overvoltage: DC bus voltage is too high. This fault occurs when the DC bus voltage exceeds the allowable value.	<ul style="list-style-type: none"> <li>• Poor setting of control parameters (with overshoot)</li> <li>• Input voltage too high</li> <li>• Interference voltage at input</li> <li>• Deceleration ramp too short</li> <li>• The brake resistor is damaged or too small</li> </ul>	<ul style="list-style-type: none"> <li>• Extended deceleration time 1-30</li> <li>• Check the input circuit and reduce the input voltage to meet the specification requirements.</li> <li>• Remove the power factor correction capacitor.</li> </ul>
<b>E.OS</b>	Over speed	Speed out of limit	<ul style="list-style-type: none"> <li>• Increase the value of 1-10 (positive maximum reference) and 1-14 (Front maximum absolute reference) to a greater value than 1-10</li> <li>• Increase 1-28 (acceleration time) and adjust the speed loop parameters 3-06 and 3-09 at the same time.</li> </ul>
<b>E. UP</b>	Under voltage: Voltage too low (DC bus). If the DC bus voltage drops below the allowable value, this fault will occur.	<ul style="list-style-type: none"> <li>• The input voltage is too low or unstable</li> <li>• Low inverter panel power</li> <li>• loss of voltage due to poor terminals</li> <li>• Generator / transformer supply voltage drops due to short ramp time</li> </ul> <p>In model F5-g with case size B, if there is no communication between power unit and control card, E.UP will also be displayed</p> <ul style="list-style-type: none"> <li>•The break factor (2-56) is too small</li> </ul>	<ul style="list-style-type: none"> <li>• Check the input circuit and supply voltage.</li> <li>• Extended acceleration time</li> </ul>

		•Edit as the digital terminal of E.U (2-65) alarm output function	
<b>E.UPh</b>	The input phase lost	One phase loss of input voltage (detection ripple)	<ul style="list-style-type: none"> <li>• check the input voltage</li> <li>•Terminal screw locking</li> </ul>
<b>E.iPH</b>	The output phase lost	Output phase detection fault	<ul style="list-style-type: none"> <li>• Check the wiring of the motor.</li> <li>• Check the capacity of motor and inverter</li> </ul>
<b>ES</b>	Emergency stop, system high pressure		
<b>CE1</b>	<p>Modbus communication error:</p> <ul style="list-style-type: none"> <li>• Communication is not received after the abnormal detection time of inverter communication.</li> <li>• After the communication is interrupted, take the free running to stop and display the alarm.</li> <li>• Automatic reset after communication is reestablished.</li> </ul>	<ul style="list-style-type: none"> <li>• The connection is broken or communication with the host has stopped.</li> </ul>	Check all connections and verify all client software architectures.
<b>COT</b>	<p>Communication error between hand recorder and UC800:</p> <ul style="list-style-type: none"> <li>• Over 92-06 (abnormal communication detection time), no communication received.</li> <li>• After the communication is disconnected, stop the inverter.</li> <li>• It is necessary to press the reset key of the hand recorder to reset</li> </ul>	<ul style="list-style-type: none"> <li>• The connection is broken or communication with UC800 has stopped.</li> </ul>	Check all connection

## 6.4 Warning Alarm / Self-Diagnosis Detection Function - 【Inverter Running】

When the inverter detects a warning, the LCD will display the warning code, the fault output contact does not act, once this warning is lifted, the system will automatically restore the original state.

When the inverter panel detects a self-diagnosis function (for example, there is an invalid setting or conflicting two parameter settings), the LCD operator will display the self-diagnosis code and the fault output contact will not act.

When a warning or self-diagnostic error occurs, refer to table 6.2 to identify and correct the resulting error.

Press the reset key at this time, the warning message will not disappear, unless the warning or self-diagnosis error still exists, the warning will disappear automatically.

**Table 6.2 Warning / Self-Diagnosis And Corrective Actions**

LCD Display	Instruction	Reasons	Corrective Actions
<b>CO_NG</b>	Bad communication	Abnormal communication times > 92_05 (Communication fault tolerance times)	Check the communication line
<b>EPR</b>	EEPROM Fault	CPU mother board EEPROM Fault.	Replace the control board.

# Chapter 7 AFE Abnormal Diagnosis And Troubleshooting

## 7.1 AFE General Rules

Fault detection and early warning / self-diagnosis function of AFE. When the AFE detects that the fault code is displayed in the LCD operator, the fault contact output acts to cut off the AFE output power grid, so that the bus voltage control function is forced to stop (in this case, in order to protect the whole machine, the AFE shutdown will also force the inverter to stop), so as to prevent the bus voltage from damaging the main capacitor due to the continuous operation of the permanent magnet motor.

## 7.2 Error Display And Resolution

Error Display	Error Display Content	Description	Solutions
PUF	Fuse blown	Main transistor damaged, AC DC circuit fuse open	Check for damaged transistors, Check input / output terminal, ground fault, etc.
UV1	Undervoltage of main circuit	During operation, the current of the main circuit is below the detection level of PUV and exceeds the ride through time of forward power loss Detection level 400V level: about $\leq 380V$ DC	<ul style="list-style-type: none"> <li>● Check the wiring of power equipment</li> <li>● Fixed power supply voltage</li> </ul>
UV2	Control circuit undervoltage	Undervoltage in control circuit	
UV3	MC answer fault	During operation, inrush current limits the open contactor	
AU <sub>v</sub>	Undervoltage of power supply	Undervoltage when running Detection level 400V level: about $\leq 300V$ DC	
FdE <sub>v</sub>	Power frequency error	The power frequency exceeds the tolerance	

SrC	Input phase error	After the control power is input, the phase circulation direction of the input is changed.	
OC	Over current	Inverter input current exceeds OC level	<ul style="list-style-type: none"> <li>● Output short circuit</li> <li>● Reduce the voltage</li> </ul>
OV	Overvoltage	DC voltage of main circuit exceeds OV level Detection level 400V level: about $\geq 800V$ DC	Regeneration load exceeded
OH	Cooling fan overheat	The cooling fan temperature exceeds the value in L8-02.	<ul style="list-style-type: none"> <li>● Check the cooling fan and surrounding temperature</li> <li>● Inspect the filter and fan</li> </ul>
OH1	Cooling fan overheat	Cooling fan temperature out of tolerance	
OL	inverter input overload	Input overload level exceeded	Reduce load

Inspect the filter and fan ( plus )

<b>Error Display</b>	<b>Error Display Content</b>	<b>Description</b>	<b>Solutions</b>	
EF3	Control circuit Terminal 3 External fault	External operation input of control circuit terminal 3	Check input terminal	
EF4	Control circuit Terminal 4 External fault	External operation input of control circuit terminal 3		
EF5	Control circuit Terminal 5 External fault	External fault of control circuit terminal 5		
EF6	Control circuit Terminal 6 External fault	External fault of control circuit terminal 6		
EF7	Control circuit Terminal 7 External fault	External fault of control circuit terminal 7		
EF8	Control circuit Terminal 8 External fault	External fault of control circuit terminal 8		
OPR	Operator failure	Running control from operator, but operator not connected		Check cables and connectors
ERR	EEPROM enter error	Unable enter EEPROM		Replace the control card
UNBC	Current imbalance	Unbalanced current between modules	<ul style="list-style-type: none"> <li>● Check the wiring of power equipment</li> </ul>	

### 7.3 OPE Error Details

OPE No.	Display Content	Description	Solution
OPE01	KVA Selecting error	Incorrect / unused selected capacity detection level Choose 600V for 400V	Check the parameters
OPE02	High / low Extreme error	The parameter is set outside the allowable range. Set above or below the lower limit.	
OPE03	Multi-function contact input selection error	Repeat the setting of parameters h1-01 ~ h1-06 exceed the same settings of 0F, FF, 20~2F	

### 7.4 CPF Error Details

Error Display	Error Display Content	Description	Solutions
CPF00	Control circuit error 1 (operation transfer error)	<ul style="list-style-type: none"> <li>The controller and the operator are not connected within 5 seconds after the power is switched on.</li> <li>MPU peripheral check error.</li> </ul>	<ul style="list-style-type: none"> <li>Reconnect the operator and connector</li> <li>Check the power supply's wiring of control circuit</li> <li>Replace the controller card</li> </ul>
CPF01	Control circuit error 2 (operation transfer error)	<ul style="list-style-type: none"> <li>The controller and operator are connected within 2 seconds after the power is switched on, but the transmission error occurs</li> <li>MPU peripheral check error.</li> </ul>	<ul style="list-style-type: none"> <li>Reconnect the operator and connector</li> <li>Check the power supply's wiring of control circuit</li> <li>Replace the controller card</li> </ul>
CPF02	Basic subprogram circuit error	Converter controller error	Replace the controller card
CPF03	EEPROM fault		
CPF04	CPU internal A / D converter failure		

CPF05	CPU-external A/D converter failure		
CPF06	Optional connection error	Optional card not connected properly	Reinsert optional card
CPF07	PWM timer error	Converter controller failure	Replace the controller card
CPF08	DPRAM BCC check error		
CPF09	DPRAM internal connection diagnostics error		
CPF10	DPRAM write error		
CPF22	Optional device code error	Connect the mismatched optional devices	Check connected optional devices
CPF24	Converter card error	Converter card A/D conversion error	Replace converter card

## 7.5 Alarm Display Details

When the door panel is removed, the alarm does not operate the error contact output, and will automatically return to the original operation state.

When displayed, the alarm flashes

Alarm Display	Alarm Display Content	Description	Solution
UV	Undervoltage detected	Main DC voltage is lower than L2-05 (undervoltage detection level) at stop or instantaneous power loss	-
OV	OV stop	DC voltage of main circuit exceeds OV level	Regeneration level exceeded
OL	Converter input overload	Input overload level exceeded	Reduce load
OH	Cooling fan overheat	The cooling fan temperature exceeds the value in L8-02.	<ul style="list-style-type: none"> <li>● Check cooling fan and surrounding temperature</li> <li>Check filter and fan</li> </ul>

EF3	Control circuit terminal 3 external failure	Input external error from control circuit terminal 3 (min. error selection)	Check input terminal
EF4	Control circuit terminal 4 external failure	Input external error from control circuit terminal 4 (min. error selection)	
EF5	Control circuit terminal 5 external failure	Input external error from control circuit terminal 5 (min. error selection)	
EF6	Control circuit terminal 6 external failure	Input external error from control circuit terminal 6 (min. error selection)	
EF7	Control circuit terminal 7 external failure	Input external error from control circuit terminal 7 (min. error selection)	
EF8	Control circuit terminal 8 external failure	Input external error from control circuit terminal 8 (min. error selection)	



# Chapter 8 Daily Use And Regular Maintenance

## 8.1 Daily Use

### 8.1.1 Daily Startup

*Note: If inverter panel trip high temperature alarm (default value is 85 degree). Please check cooling water temperature and flow.*

*Please regularly check and flush Y type filter in front of input cooling water hose.*

### 8.1.2 Seasonal Switch

Seasonal Shutdown: Please drain water in the inverter water cooling system.

Seasonal Boot: Open the frequency converter water cooling system and inverter condition.

### 8.1.3 Anti Condensation Operation Of Inverter Panel

For inverter panel operating in the low condenser water temperature or high humidity environment.

Please select the anti-condensation type inverter panel.

Before running, check the power supply, incoming line and outlet terminal of inverter panel and make sure the seal is good.

The doors should be remained closed for all anti-condensation type inverter panels.

## 8.2 Maintenance

### 8.2.1 Filter Cleaning Method And Period

Before the removal and cleaning of Y-type filter, close the ball valve at the connecting pipe of condenser water chamber, remove the screw plug at the downside of Y-type filter, draw out the filter net for cleaning, open the ball valve at the front of the filter slightly at the same time, and flush the removal port; complete the cleaning and reassemble in time. Open the ball valve at the connecting pipe of condenser water chamber.

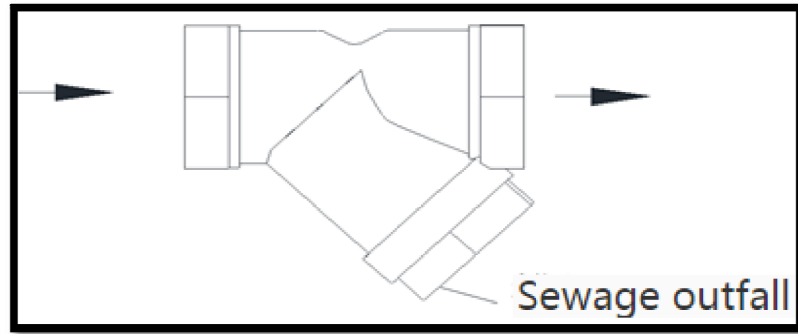

Figure 8.1 Y Filter of Cooling Water System

If the water quality of the customer's cooling water meets the standard and is in good condition, and the customer has done a good job in maintenance, it is recommended to use a filter net with less than 60 mesh. However, in the actual market application, sundries in the customer's cooling water will inevitably enter the cooling water system. If the customer's maintenance is not good enough, it will often be dirty and blocked, resulting in the overheat shutdown of the water-cooled inverter panel. It is recommended to use no less than 20 mesh filters. Replacement is recommended annually.

**Table Y filter cleaning period reference**

Quality of cooling water	Recommended filter Period
Water quality is superior to the national standard (GB/T29044-2012)	6 months
Water quality conforming to the national standard (GB/T29044-2012)	3 months
Water quality close to the national standard (GB/T29044-2012)	1-2 months
Water quality not in conformity with national standard (GB/T29044-2012)	1 week-1 month

## 8.2.2 Maintenance, Cleaning And Replacement Of Plate

The heat exchanger is recommended to be replaced in 3~5 year.

Failure factors and treatment

### 1) Scaling

Only the cooling water side of the heat exchanger suitable to clean by chemicals. If heat exchanger fouling blocked, please reverse flushing with an acid cleaning agent (5% phosphoric acid or peroxide acid). In order to improve the flushing performance, the water pump can be used to flush heat exchanger. The optimum flushing flow rate is 1.3~1.5 times of the original liquid flow rate. Rinse the acidic cleaning agent with clean water after washing, and test with PH paper after washing to check whether the cleaning agent is washed clean.

Note: Remain acid chemicals inside heat exchanger may damage pipe and cause leakage.

It is recommended to employ qualified water treatment specialists to determine which water treatment is suitable. Recommended flushing method as following:

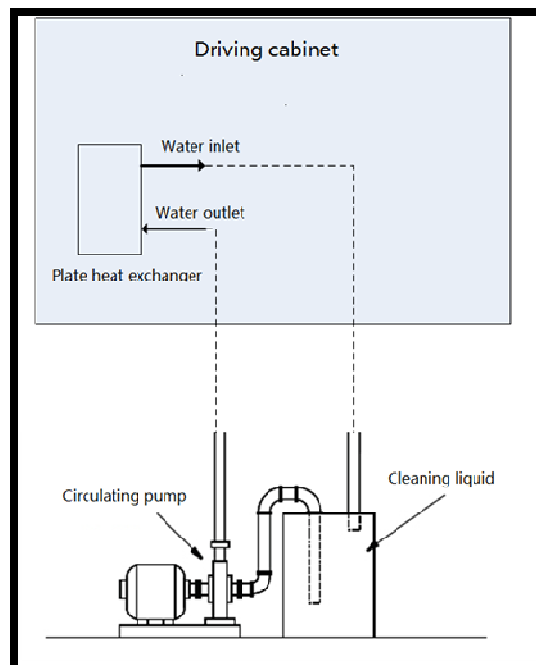

Figure 8.2 cleaning arrangement of heat exchanger

## 2) Dirty Blockage

In the actual use of the water-cooled inverter cabinet for air conditioning, if the customer department is not equipped with a filter or the filter fails, the efficiency of the heat exchanger will be reduced or fail, and according to market experience, most of the heat exchange failures are caused by dirty blockage.

## 3) Destroy

According to the characteristics and structure of the brazed plate heat exchanger, the plate is formed once (usually it can't be repaired and can only be replaced). Therefore, in case of damage, only replace to the new products.

### 1. The Edge of Heat Exchanger Leakage:

When this happens, it is generally impossible to maintain, because the heat exchanger used for the brazing flux low temperature. The high temperatures produced by repair welding tend to melt nearby brazing material, causing leakage elsewhere in the vicinity.

### 2. Leakage or Cracks of Heat Exchanger Connector

The situation is more optimistic than the peripheral leakage, but the maintenance is still difficult.

### 3. Internal or External Leakage of Heat Exchanger

As the brazed plate heat exchanger is of welding type, it can only be replaced in this case.

## **8.2.3 Replacement Period Of Coolant, Coil And Water Pump**

- 1) The anti-freezing coolant proposed replacement period is 24 months.
- 2) Radiator inside inverter panel proposed replacement period is 60 months.
- 3) Water pump is maintenance free, normal life span is 8-10 consecutive years.

**Note: if the heat exchanger is dirty due to long service time or poor environmental water quality, which affects the heat conduction effect, the manufacturer recommends replacing it directly instead of cleaning it.**



## 乐金空调（山东）有限公司

24 小时全国免费服务电话. 400-819-8008

地址. 山东省青岛市城阳区夏庄街道玉皇岭工业园

邮编. 266109

网址. [www.lgeqa.com](http://www.lgeqa.com)